DS8100

Installation Manual

DATALOGIC DL
Bar Code & More
.....

DS8100

INSTALLATION MANUAL



We

DATALOGIC S.p.A.
Via Candini, 2
40012 - Lippo di Calderara
Bologna - Italy

declare under our sole responsibility that the product

DS8100-XXXX, Laser Scanner and all its models

to which this declaration relates is in conformity with the following standards or other normative documents

EN 55022, August 1994: LIMITS AND METHODS OF MEASUREMENTS OF RADIO DISTURBANCE CHARACTERISTICS OF INFORMATION TECHNOLOGY EQUIPMENT (ITE)

EN 50082-2, March 1995: ELECTROMAGNETIC COMPATIBILITY. GENERIC IMMUNITY STANDARD. PART 2: INDUSTRIAL ENVIRONMENT

EN 60950, October 1996: SAFETY OF INFORMATION TECHNOLOGY EQUIPMENT, INCLUDING ELECTRICAL BUSINESS EQUIPMENT

EN 60825, March 1993: RADIATION SAFETY OF LASER PRODUCTS, EQUIPMENT CLASSIFICATION, REQUIREMENTS AND USER'S GUIDE

Following the provision of the Directive(s):

89/336 CEE AND SUCCESSIVE AMENDMENTS, 92/31 CEE; 93/68 CEE; 73/23 CEE

Lippo di Calderara, 23.03.1998

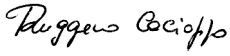
Ruggero Cacioppo

Quality Assurance Supervisor

Product names mentioned herein are for identification purposes only and may be trademarks and or registered trademarks of their respective companies.

Datalogic reserves the right to make modifications and improvements without prior notification.

© 1998 Datalogic S.p.A.

821000163 (Rev. C)

CONTENTS

General view	v
SAFETY PRECAUTIONS	vii
Electrical Safety	vii
Laser Safety.....	vii
Standard Regulations	vii
Power Supply.....	ix
1. GENERAL FEATURES	1.1
1.1 Introduction.....	1.1
1.2 Description	1.3
1.2.1 Indicators - DS8100 Serial Interface	1.4
1.2.2 Indicators - DS8100 Bus Interface	1.4
1.3 Available Models	1.5
1.4 Accessories.....	1.5
1.5 Applications	1.6
2. INSTALLATION - DS8100 SERIAL INTERFACE.....	2.1
2.1 Package Contents	2.1
2.2 Guide To Installation.....	2.2
2.3 Opening The Scanner.....	2.3
2.3.1 Main Interface Selection	2.4
2.3.2 Multidrop Address Selection	2.5
2.4 Mechanical Installation	2.6
2.5 Electrical Connections	2.7
2.5.1 DS8100 Connectors	2.7
2.5.2 Power Supply.....	2.10
2.5.3 Main Serial Interface.....	2.10
RS232 Interface.....	2.11
RS485 Full-Duplex Interface.....	2.12
RS485 Half-Duplex Interface	2.13
20 mA Current Loop Interface	2.15
2.5.4 Auxiliary Interface	2.16
RS232 Auxiliary Interface	2.16
RS485 Half-Duplex Auxiliary Interface	2.17
2.5.5 Inputs	2.17
2.5.6 Outputs	2.21
2.6 Positioning	2.22

2.7	Typical Layouts	2.24
2.7.1	Standard (Point-to-Point)	2.24
2.7.2	Pass Through	2.25
2.7.3	RS485 Master/Slave	2.26
2.7.4	Multiplexer	2.27
2.7.5	Omnidirectional Reading	2.28
3.	INSTALLATION — DS8100 BUS INTERFACE	3.1
3.1	Package Contents	3.1
3.2	Guide To Installation	3.2
3.3	Mechanical Installation	3.3
3.4	Electrical Connections	3.4
3.4.1	Power Supply	3.5
3.4.2	Inputs	3.6
3.5	Positioning	3.7
3.6	Typical Layout	3.8
4.	READING FEATURES	4.1
4.1	Code Reconstruction	4.1
4.1.1	The Tilt Angle For Code Reconstruction	4.1
4.2	Performance	4.2
4.3	Reading Diagrams	4.3
5.	MAINTENANCE	5.1
5.1	Cleaning	5.1
6.	TECHNICAL FEATURES	6.1

DS8100 General View

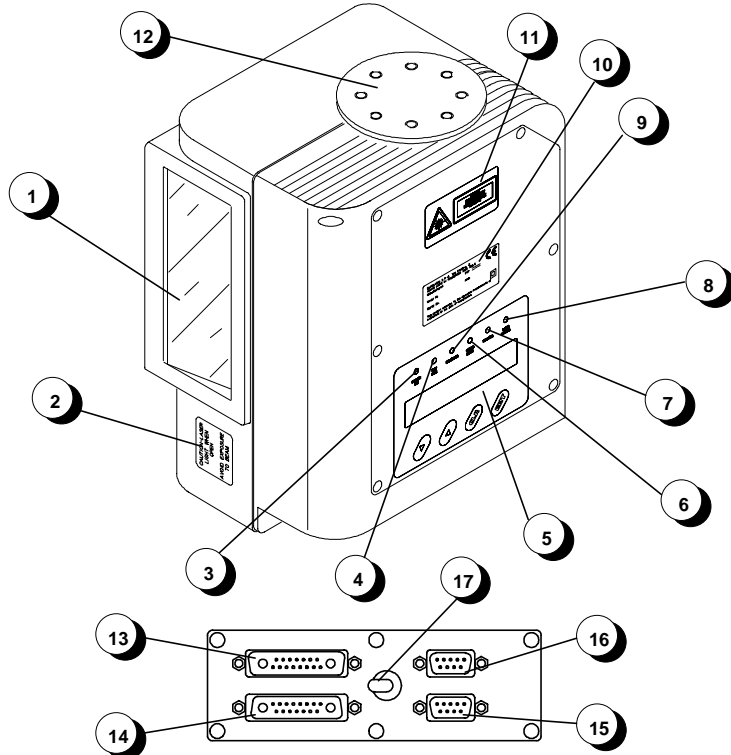

- | | |
|----------------------------|---|
| ① Laser Beam Output Window | ⑩ Product Label |
| ② Laser Safety Label | ⑪ Warning and Device Class Label |
| ③ Power ON LED | ⑫ Mounting Holes |
| ④ Ext Trig LED | ⑬ Aux. Interface/Input Signal Connector A |
| ⑤ Keypad and Display | ⑭ Aux. Interface/Input Signal Connector B |
| ⑥ Good Read LED | ⑮ Main Interface Connector |
| ⑦ TX Data LED | ⑯ Output Signal Connector |
| ⑧ User Signal LED | ⑰ Laser Beam and Motor Power Switch |
| ⑨ Encoder LED | |

Figure A - DS8100 Serial Interface version

DS8100 General View

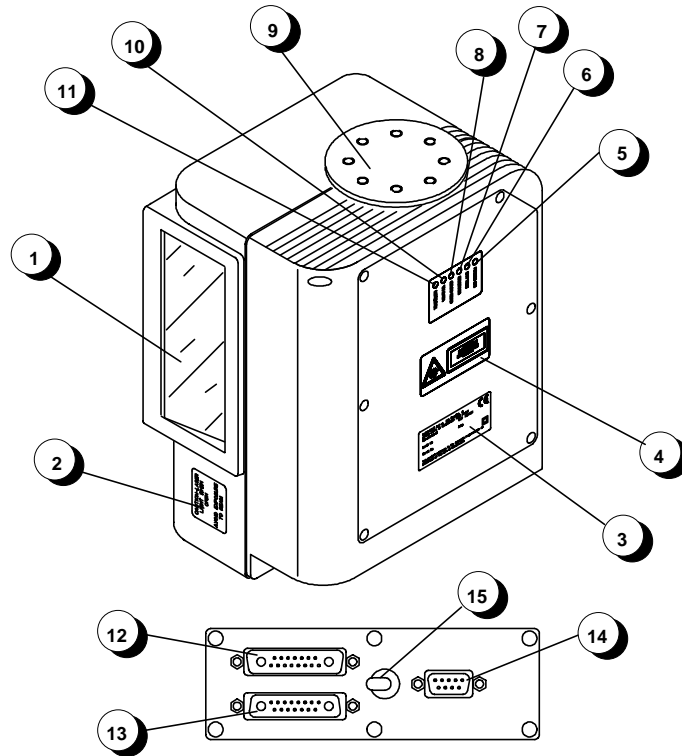

- | | |
|----------------------------------|-------------------------------------|
| ① Laser Beam Output Window | ⑨ Mounting Holes |
| ② Laser Safety Label | ⑩ TX Data LED |
| ③ Product Label | ⑪ Network LED |
| ④ Warning and Device Class Label | ⑫ Lonworks Input Connector |
| ⑤ Power ON LED | ⑬ Lonworks Output Connector |
| ⑥ Ext Trig LED | ⑭ RS232 Debug Connector |
| ⑦ Encoder LED | ⑮ Laser Beam and Motor Power Switch |
| ⑧ Good Read LED | |

Figure B - DS8100 Bus Interface version

SAFETY PRECAUTIONS

ELECTRICAL SAFETY

This product conforms to the applicable requirements contained in the European Standard for electrical safety EN-60950 at the date of manufacture.



This symbol refers to operations that must be performed by qualified personnel only. Example: opening the device.



This symbol refers to operations where there is danger of electrical shock. Before opening the device make sure the power cable is disconnected to avoid electric shock.

LASER SAFETY

The following information is provided to comply with the rules imposed by international authorities and refers to the correct use of the DS8100 scanner.

Standard Regulations

This scanner utilizes up to 4 low-power laser diodes. Although staring directly at the laser beam momentarily causes no known biological damage, avoid staring at the beam as one would with any very strong light source, such as the sun. Avoid that the laser beam hits the eye of an observer, even through reflective surfaces such as mirrors, etc.

This product conforms to the applicable requirements of both IEC 825-1 and CDRH 21 CFR 1040 at the date of manufacture. The scanner is classified as a Class 2 laser product according to IEC 825-1 regulations and as a Class II laser product according to CDRH regulations.

There is a safety device which allows the laser to be switched on only if the motor is rotating above the threshold for its correct scanning speed.

WARNING

Use of controls or adjustments or performance of procedures other than those specified herein may result in exposure to dangerous laser radiation.

The laser light is visible to the human eye and is emitted from the window on the side of the reader (Figure A, ① and Figure B, ①).

Warning labels indicating exposure to laser light and the device classification are applied onto the body of the scanner (Figure A, ②, ⑩ and ⑪, Figure B, ②, ③ and ④):

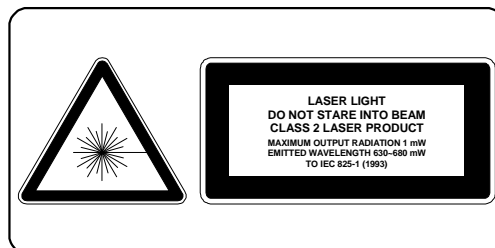
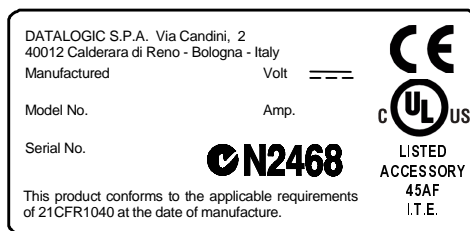
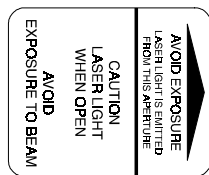

Warning and device class labels

Disconnect the power supply when opening the device during maintenance or installation to avoid exposure to hazardous laser light.

The laser diodes used in this device are classified as Class 3B laser products according to IEC 825-1 regulations and as Class IIIb laser products according to CDRH regulations. As it is not possible to apply a classification label on the laser diodes used in this device, the following label is reproduced here:

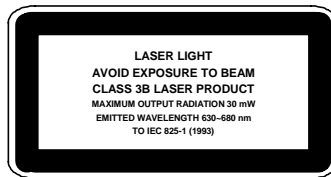

Laser diode class label

Any violation of the optic parts in particular can cause radiation up to the maximum level of the laser diode (30 mW at 630-680 nm).

POWER SUPPLY

This scanner is intended to be supplied by either a UL Listed power supply marked 'Class 2' or 'LPS', output rated 20 - 30 V dc , minimum 1.0 A or by a UL Listed computer with LPS outputs.

In any case, all models of DS8100 must be supplied by a Class II Power Supply Unit conforming to the EN 60950 safety regulation.

This page is intentionally left blank.

1 GENERAL FEATURES

1.1 INTRODUCTION

The DS8100 scanner is a barcode reader complete with decoder designed to provide an innovative and high performance solution in omnidirectional reading applications by combining the following advanced technologies with Datalogic's solid experience in the material handling sector.

ACR™

Advanced Code Reconstruction technology allows the reading of low aspect ratio labels placed anywhere on a parcel and enhances the readability of poorly printed or damaged codes.

CD SQUARE™

CD SQUARE™ provides useful information on label position and object shape elaborated during the barcode reading phase. This innovative technology identifies the area in which the code is located and measures the code distance from the scanner.

PACKTRACK™

PackTrack™ is a Datalogic patented parcel tracking system which improves the reading features in omnidirectional stations. In particular, PackTrack™ manages 6-sided reading systems when it is impossible to detect the real position of the code on the parcel, thus overcoming the need for external accessories essential in traditional tracking systems.

ASTRA™

Automatically SwITched Reading Area™ is the new Datalogic technology based on a multi-laser architecture and a fixed mounted optic system which concentrates the multiple laser emissions in a single laser beam. As each laser emitter is focused on a specific range of the reading area, a sophisticated electronic controller selects the best focused laser emitter with

respect to the code to read. This allows the reading of medium-high density codes in a large reading area on very fast conveyors.

TBS™

Twin Beam System™ improves the reading of codes covered by plastic film or wrapping material. The optic architecture is able to change the laser diode path and to adapt the beam's skew angle on the code to read. This makes the scanner insensitive to direct reflections and to the bars' distortion caused by the plastic film.

Single-scanner and Multi-scanner Applications

DS8100 Serial Interface version is provided with two standard interfaces allowing easy use and connection and is therefore suitable for single-reader applications.

DS8100 Bus Interface version is particularly suited for multi-scanner applications. It is provided with a Lonworks network for connections with other DS8100s and with an SC8000 unit which performs real time data collection and control of the reading station.

Flexibility

The high frequency laser diode modulation system guarantees complete immunity to ambient light and allows installation of the DS8100 in any working area.

The DS8100 Serial Interface is easy configurable by means of the Windows-based user-friendly Winhost utility program provided on diskette. It can also be configured from a Host PC through the Host Mode procedure or using the built-in keypad through the Keyboard Mode procedure.

1.2 DESCRIPTION

Some of the main features of DS8100 are listed below:

- scanning speed 1000 scans/sec. for standard models; higher speeds available on request.
- reads all popular codes.
- supply voltage from 20 to 30 Vdc.
- test modes to verify the reading features and exact positioning of the scanner without the need for external tools.
- programmable in 5 different operating modes to suit the most various barcode reading system requirements.
- light source: solid state laser diodes; the light emitted has a wave length of 630~680 nm. For laser safety precautions refer to the "Safety precautions" section at the beginning of this manual.
- 2 serial communication interfaces for Serial Interface models.

1.2.1 Indicators - DS8100 Serial Interface

The DS8100 Serial Interface has six LEDs and an LCD display on the front panel. The indicators have the following functions:

- Power ON:** LED (green). Indicates the scanner is ON. (Figure A, ③).
- Ext Trig:** LED (yellow). Indicates the external presence sensor is active. (Figure A, ④).
- Encoder:** LED (yellow). Indicates the external encoder signal is active (when provided). (Figure A, ⑨).
- Good Read:** LED (red). Indicates a code is present in the reading zone. (Figure A, ⑥).
- TX Data:** LED (green). Indicates data transmission both on the main and on the auxiliary interface. (Figure A, ⑦).
- User Defined:** LED (red). The use of this indicator depends on the application. (Figure A, ⑧).
- LCD display:** The LCD displays messages relative to the DS8100 configuration and to the code read after decoding. It is a 2 x 20 character display. (Figure A, ⑤).

1.2.2 Indicators - DS8100 Bus Interface

The DS8100 Bus Interface has six LEDs on the rear panel.

The indicators have the following functions:

- Power ON:** LED (red). Indicates the scanner is ON. (Figure B, ⑤).
- Ext Trig:** LED (yellow). Indicates the external presence sensor is active. (Figure B, ⑥).
- Encoder:** LED (green). Indicates the external encoder signal is active (when provided). (Figure B, ⑦).
- Good Read:** LED (red). Indicates a probable code is present in the reading zone. (Figure B, ⑧).
- TX Data:** LED (green). Indicates data transmission both on the main and on the auxiliary interface. (Figure B, ⑩).
- Network:** LED (red). In a normal situation, this LED is OFF. If the LED blinks, check the connections between the DS8100 and the SC8000. When this LED is ON, the network card needs to be reprogrammed. Contact your Datalogic distributor. (Figure B, ⑪).

1.3 AVAILABLE MODELS

The DS8100 scanner is available in four versions that differ depending on the system of connection and on the laser number:

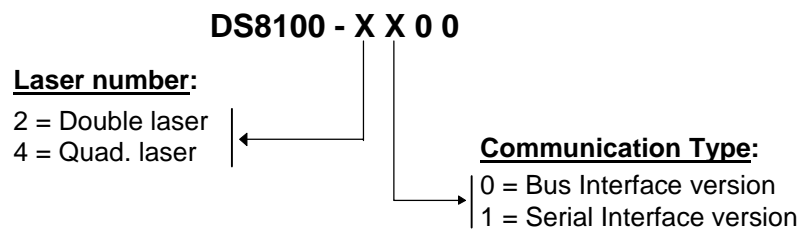

1.4 ACCESSORIES

The following DS8100 accessories are available on request:

- Power supply unit
- 90° deflection mirror
- Oscillating mirror
- XMF-10 Single cross metal frame
- XMF-20 Double cross metal frame
- FBK-8100 Fast bracket kit
- US-8100 Bracket kit
- CAB-8101 1.2 m. DS8100-DS8100 Connection cable
- CAB-8102 2.5 m. DS8100-DS8100 Connection cable
- CAB-8105 5 m. DS8100-DS8100 Connection cable
- CAB-8005 5 m. DS8100-SC8000/Host Connection cable
- CAB-8010 10 m. DS8100-SC8000/Host Connection cable
- BTK-8100 Bus terminator kit for DS8100 Lonworks version

1.5 APPLICATIONS

The DS8100 barcode reader is specifically designed for industrial applications and for all cases requiring high reading performance such as:

- code reconstruction
- reading of codes covered by plastic film
- reading of codes with a wide depth of field
- reading of high resolution codes positioned at long distances from the reader
- barcode reading combined with parcel dimensioning
- code reading on fast moving objects.

DS8100 is designed for both single-reader layouts and multi-reader layouts. For typical layouts see par. 2.7 and 3.6.

2 INSTALLATION — DS8100 SERIAL INTERFACE

2.1 PACKAGE CONTENTS

Verify that the DS8100 reader and all the parts supplied with the equipment are present and intact when opening the packaging; the list of parts includes:

1. DS8100 reader
2. Installation Manual + barcode test chart
3. DS8100 configuration disk
4. Mounting bracket and screws

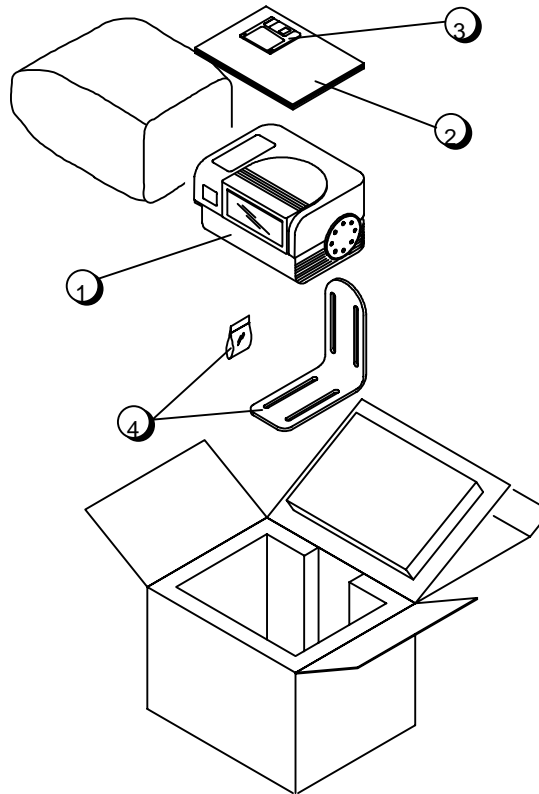

Figure 2.1 - DS8100 package contents

2.2 GUIDE TO INSTALLATION

The following can be used as a checklist to verify all the necessary steps for complete installation of the DS8100 scanner.

1. Read all information in the section Safety Precautions at the beginning of this manual.
2. Correctly position and mount the scanner for barcode reading according to the information in paragraphs 2.3, 2.4 and 2.6.
3. Provide correct system cabling according to the signals necessary (see all applicable sub-paragraphs under 2.5).
4. Install the Configuration Disk and configure the software parameters from a host computer using one of the following methods:
 - WINHOST interface utility program. For more details refer to the section “DS8100 Configuration” in the WINHOST Help On Line.
 - Host Mode programming procedure by ESC sequences via the serial interface. For more details refer to the Word document [hds8100.doc](#) in the DS8100 directory.
 - Keyboard Mode through the keypad and the display. For more details refer to the Word document [kds8100.doc](#) in the DS8100 directory.

NOTE

Fine tuning of the scanner position for barcode reading can be accomplished using the [Test Mode](#) as described in WINHOST.

The installation is now complete.



2.3 OPENING THE SCANNER

Before installing the DS8100 Serial Interface model, it may be necessary to open the scanner to select the Main interface type and the Multidrop Address (see par. 2.3.1 and 2.3.2)

WARNING

Before unscrewing the display panel of the DS8100, make sure the power supply cable is disconnected to avoid shock or harm to the operator.



The following operation should be performed by qualified personnel only.

Refer to the following instructions and Figure 2.2 when opening the reader:

1. The part of the device to be opened is the display panel.
2. Unscrew the six screws to open the scanner.
3. Carefully remove the panel as shown in Figure 2.2.

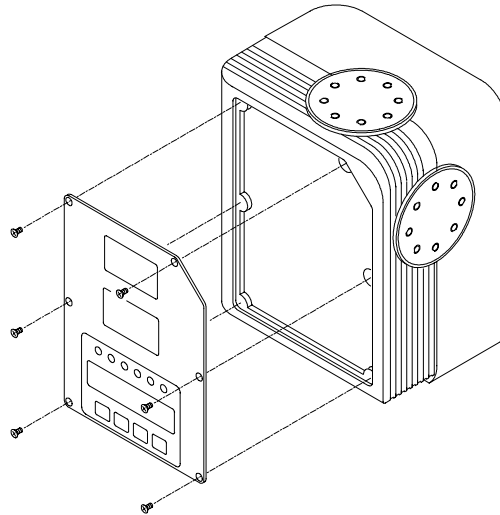

Figure 2.2 - Opening the DS8100



2.3.1 Main Interface Selection

The main serial interface of the DS8100 offers the following communication types:

- RS232**
- RS485 full-duplex**
- RS485 half-duplex**
- 20 mA current loop**

The RS232 interface is factory set.

To select the interface type:

1. Remove the panel as described in par. 2.3.
2. Position the jumper onto the correct connector as indicated in Figure 2.3.

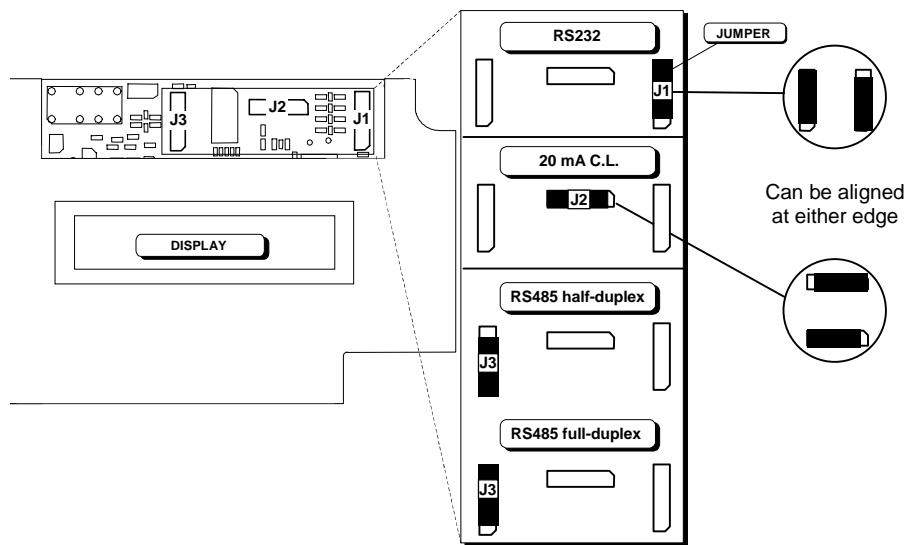

Figure 2.3 - DS8100 main interface selection



2.3.2 Multidrop Address Selection

When using the RS485 half-duplex interface, the Multidrop Address must be selected. Proceed as follows:

1. Open the panel as described in par. 2.3.
2. Position the switches as desired, referring to Figure 2.4.

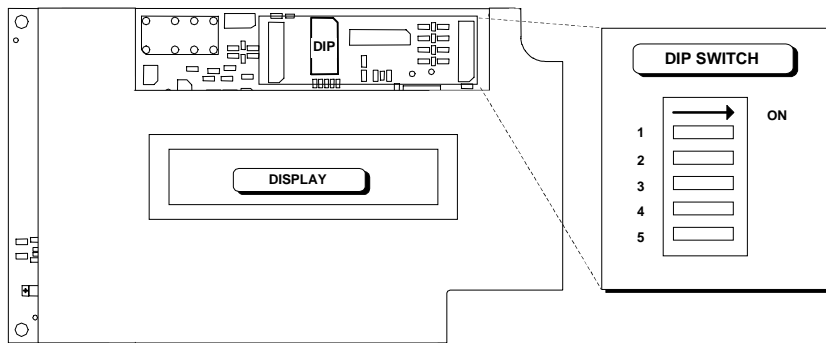

Figure 2.4 - DS8100 Multidrop Address selection

The following table shows the Multidrop Address settings where:

1 = ON 0 = OFF

Position					Address	Position					Address
5	4	3	2	1		5	4	3	2	1	
1	1	1	1	1	31	0	1	1	1	1	15
1	1	1	1	0	30	0	1	1	1	0	14
1	1	1	0	1	29	0	1	1	0	1	13
1	1	1	0	0	28	0	1	1	0	0	12
1	1	0	1	1	27	0	1	0	1	1	11
1	1	0	1	0	26	0	1	0	1	0	10
1	1	0	0	1	25	0	1	0	0	1	9
1	1	0	0	0	24	0	1	0	0	0	8
1	0	1	1	1	23	0	0	1	1	1	7
1	0	1	1	0	22	0	0	1	1	0	6
1	0	1	0	1	21	0	0	1	0	1	5
1	0	1	0	0	20	0	0	1	0	0	4
1	0	0	1	1	19	0	0	0	1	1	3
1	0	0	1	0	18	0	0	0	1	0	2
1	0	0	0	1	17	0	0	0	0	1	1
1	0	0	0	0	16	0	0	0	0	0	0

2.4 MECHANICAL INSTALLATION

DS8100 can be installed to operate in any position.

There are 16 screw holes (M6 X 8) on the sides of the scanner for mounting. The diagram below gives all the information required for installation; refer to par. 2.6 for correct positioning of the scanner with respect to the code passage zone.

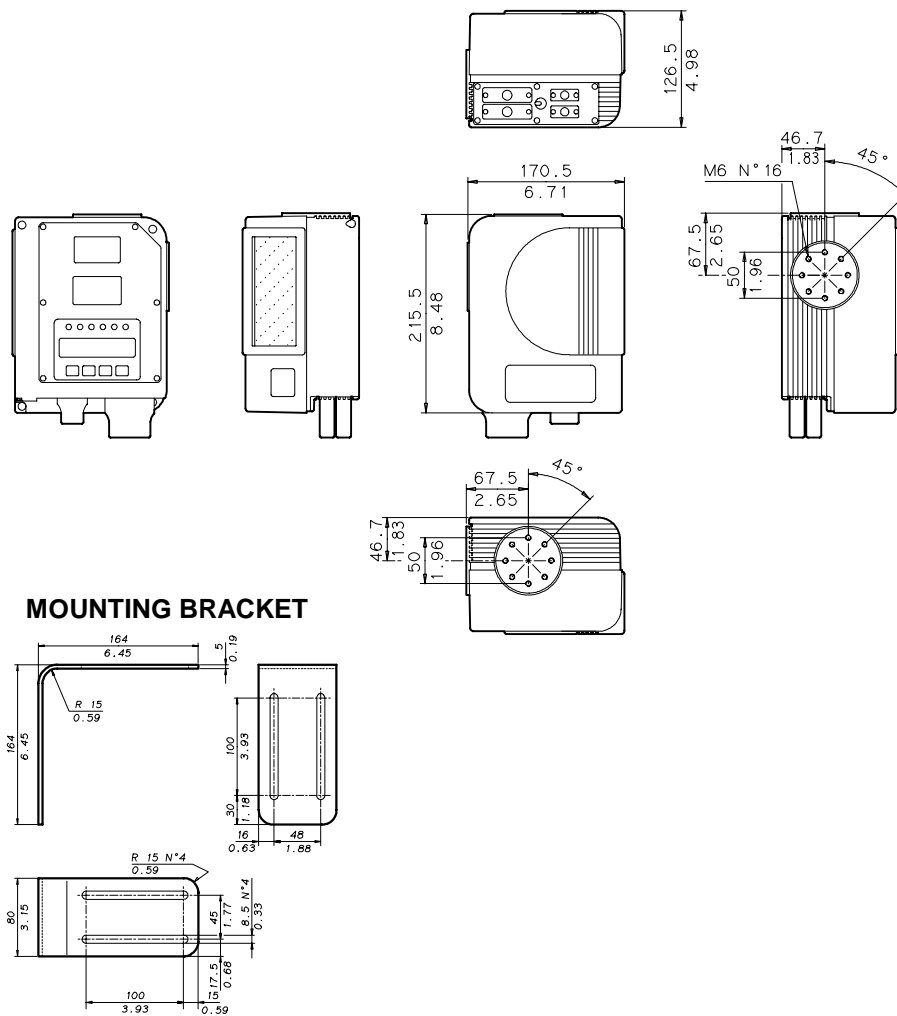

Figure 2.5 - DS8100 overall dimensions

2.6 - Installation — DS8100 Serial Interface

2.5 ELECTRICAL CONNECTIONS

2.5.1 DS8100 Connectors

The DS8100 Serial Interface version is equipped with 4 connectors for the following signals:

- Aux. Interface/Input Signal connector **A** (male, 17 pins) (Figure A, 13).
- Aux. Interface/Input Signal connector **B** (female, 17 pins) (Figure A, 14).
- Output Signal connector (female, 9 pins) (Figure A, 16).
- Main Interface connector (female, 9 pins) (Figure A, 15).

Aux. Interface/Input Signal Connector A

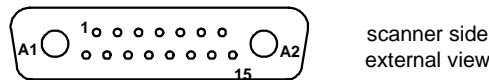

Figure 2.6 - Aux. Interface/Input Signal connector A (male)

Aux. Interface/Input Signal Connector A pinout		
Pin	Name	Function
A1	GND	Ground
A2	VS	Power Supply
1	GND485	RS485 Ground Reference
2	NC	Not connected
3	NC	Not connected
4	NC	Not connected
5	NC	Not connected
6	NC	Not connected
7	NC	Not connected
8	RXTX485+	Positive Transmit/Receive
9	RXTX485-	Negative Transmit/Receive
10	ENC+	Encoder signal (Positive pin)
11	ENC-	Encoder signal (Negative pin)
12	PS2+	Presence Sensor 2 signal (Positive pin)
13	PS2-	Presence Sensor 2 signal (Negative pin)
14	PS1+	Presence Sensor 1 signal (Positive pin)
15	PS1-	Presence Sensor 1 signal (Negative pin)

Aux. Interface/Input Signal Connector B

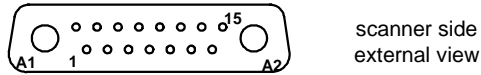

Figure 2.7 - Aux. Interface/Input Signal connector B (female)

Aux. Interface/Input Signal Connector B pinout		
Pin	Name	Function
A1	GND	ground
A2	VS	power supply
1	GND485	RS485 ground reference
2	I.U. (TXDEBUG)	only for service use
3	I.U. (GNDDEBUG)	only for service use
4	I.U. (RXDEBUG)	only for service use
5	GND AUX232	auxiliary RS232 ground
6	RX AUX232	auxiliary RS232 input
7	TX AUX232	auxiliary RS232 output
8	RXTX485+	positive RS485 transmit/receive
9	RXTX485-	negative RS485 transmit/receive
10	ENC+	encoder signal (positive pin)
11	ENC-	encoder signal (negative pin)
12	PS2+	presence sensor 2 signal (positive pin)
13	PS2-	presence sensor 2 signal (negative pin)
14	PS1+	presence sensor 1 signal (positive pin)
15	PS1-	presence sensor 1 signal (negative pin)

Output Signal Connector

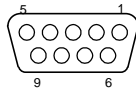

Figure 2.8 - Output Signal connector

Output Signal Connector pinout		
Pin	Name	Function
1	VS	supply voltage (positive pin)
2	GND	supply voltage (negative pin)
3	NO READ+	no read output (positive pin)
4	NO READ-	no read output (negative pin)
5	RIGHT+	right code output (positive pin)
6	RIGHT-	right code output (negative pin)
7	I.U.	internal use
8	I.U.	internal use
9		

Main Interface Connector

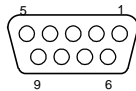

Figure 2.9 - Main Interface connector

Main Interface Connector pinout				
Pin	RS232	RS485 full-duplex	RS485 half-duplex	20 mA C.L.
1				DRVREF
2	TXD	TX485+	RTX485+	CLOUT+
3	RXD	TX485-	RTX485-	CLOUT-
4				DRVIN
5	GND	GNDRS485	GNDRS485	
6			RS485CNTR	
7	CTS	RX485+		CLIN+
8	RTS	RX485-		CLIN-
9				DRVOUT

* The function of these pins depends on the interface type selected.

2.5.2 Power Supply

The supply voltage for correct operation of the scanner must be between 20 and 30 VDC.

The max. power consumption is 30 W.

The power supply unit (optional) supplies the power necessary for the DS8100 and allows mains power to be used.

A security system allows the laser to activate only once the motor has reached the correct rotational speed; consequently, the laser beam is generated after a slight delay from the power on of the scanner.

The switch (Figure A, 17) on the connector panel turns off power to both the motor and the laser beams.

During power up of the scanner there is a current peak of about 3A caused by the motor startup.

2.5.3 Main Serial Interface

The main serial interface of the DS8100 Serial Interface version is compatible with the following electrical standards:

RS232
RS485 full-duplex
RS485 half-duplex
20 mA current loop

The configuration parameters of the selected interface can be defined using one of the programming methods available. For this procedure refer to the WINHOST Help On Line shipped on the diskette.

The connections regarding the interface selected are described in the following sections.

NOTE

The signals relative to the selected interface are only available on the Main Interface connector if the jumper inside the scanner is correctly positioned. Refer to par. 2.3.1 for further details.

RS232 Interface

The main serial interface is used in this case for point to point connections; it handles communication with the Host computer and allows both transmission of code data and configuring the scanner.

The following pins of the Main Interface connector (Figure A, 15) are used for RS232 interface connection:

Pin	Name	Function
2	TXD	transmitted data
3	RXD	received data
5	GND	ground
7	CTS	clear to send
8	RTS	request to send

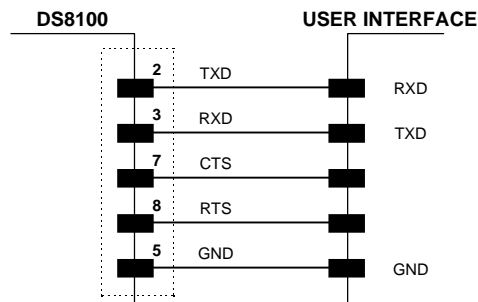

Figure 2.10 - RS232 connections

The RTS and CTS signals control data transmission and synchronize the connected devices.

If the RTS/CTS hardware protocol is enabled, the DS8100 activates the RTS output to indicate a message can be transmitted. The receiving unit must activate the CTS input to enable the transmission.

RS485 Full-Duplex Interface

The RS485 full-duplex interface is used for non-pollled communication protocols in point to point connections over longer distances than those acceptable for RS232 communications or in electrically noisy environments.

The following pins of the Main Interface connector (Figure A, ①5) are used for RS485 full-duplex communications:

Pin	Name	Function
2	TX485+	RS485 transmitted data +
3	TX485-	RS485 transmitted data -
5	GNDRS485	RS485 ground reference
7	RX485+	RS485 received data +
8	RX485-	RS485 received data -

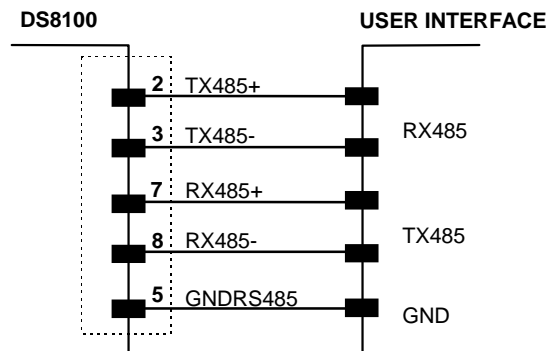

Figure 2.11 - RS485 full-duplex interface connections

RS485 Half-Duplex Interface

The RS485 half-duplex (3 wires + shield) interface is used for polled communication protocols. It can be used for Multidrop connections in a master/slave layout or with a Datalogic Multiplexer, (see par. 2.7.3, 2.7.4 and 2.7.5).

Device connection to the Multidrop line can be controlled externally through the RS485CNTR line. For example, it may be necessary to disconnect a scanner from the line if the device is damaged or the line is overloaded. To do this, apply a voltage from 20 to 30 Vdc to the RS485CNTR signal using the same GND of the power supply as a reference.

The following pins of the Main Interface connector (Figure A, 15) are used for RS485 half-duplex interface connection:

Pin	Name	Function
6	RS485CNTR	multidrop device disconnect
2	RTX485+	transmit/receive data +
3	RTX485-	transmit/receive data -
5	GNDRS485	RS485 ground reference

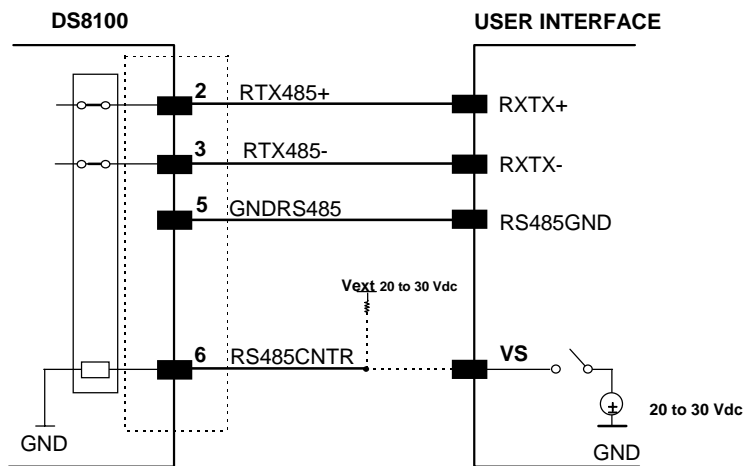

Figure 2.12 - RS485 half-duplex interface connections

The figure below shows an example of a multidrop configuration between a Multiplexer and DS8100 scanners.

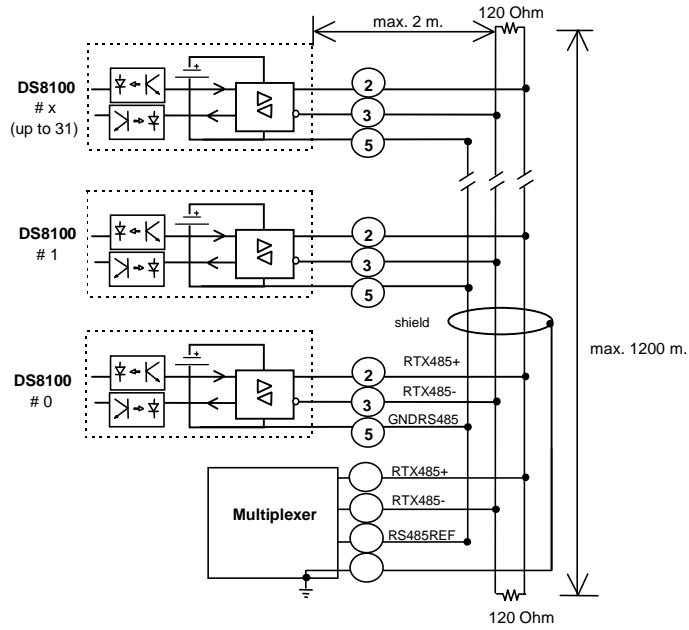

Figure 2.13 - DS8100 Multidrop connection to a Multiplexer

20 mA Current Loop Interface

The DS8100 has two current generators (one for transmission and one for reception), allowing for both active and passive type connections.

The following pins of the Main Interface connector (Figure A, 15) are used for 20 mA C.L. connections:

Pin	Name	Function
1	DRVREF	current generator reference
2	CLOUT+	current loop output +
3	CLOUT-	current loop output -
4	DRVIN	input current generator
7	CLIN+	current loop input +
8	CLIN-	current loop input -
9	DRVOU	output current generator

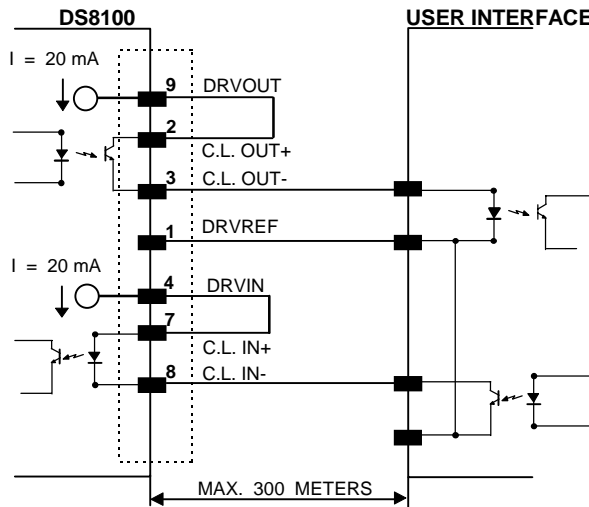

Figure 2.14 - 20 mA C.L. active connections

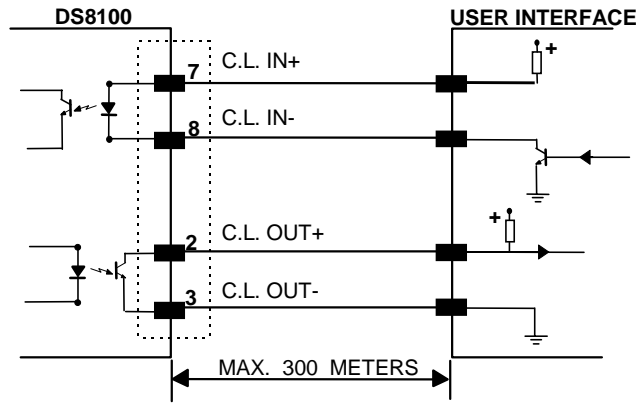

Figure 2.15 - 20 mA C.L. passive connections

2.5.4 Auxiliary Interface

The auxiliary serial interface of the DS8100 Serial Interface version is equipped with both RS232 and RS485 half-duplex interface connections.

The signals for the auxiliary interface are available on the **Aux. Interface A** and **B** connectors to simplify the master/slave connections (Figure A, 13 and 14).

RS232 Auxiliary Interface

The following pins of the **Aux. Interface B connector** are used:

Pin	Name	Function
5	GNDAUX232	ground
6	RXAUX232	receive data
7	TXAUX232	transmit data

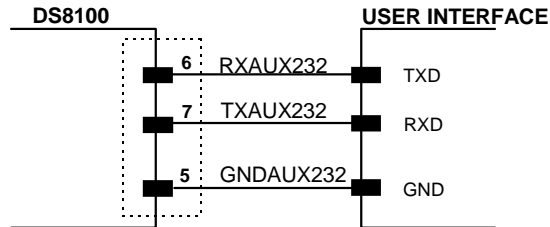

Figure 2.16 - RS232 Auxiliary interface connections

RS485 Half-Duplex Auxiliary Interface

The following pins of the **Aux. Interface A and B connectors** (Figure A, 13 and 14) are used:

Pin	Name	Function
1	GND485	ground
8	RTX485+	transmit/receive data +
9	RTX485-	transmit/receive data -

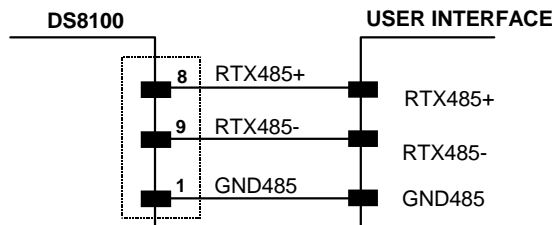

Figure 2.17 - RS485 Auxiliary interface connections

2.5.5 Inputs

The inputs of the scanner are on the **Input Signal A and B connectors** on the body of the DS8100 (Figure A, 13 and 14).

These inputs are called ENC, PS1 and PS2.

ENC is the Encoder input. In PackTrack™ operating mode, it detects the conveyor speed.

PS1 is the main presence sensor (external trigger). When active, this input tells the scanner to scan for a code and that decoding can take place. The yellow LED (Figure A, 4) indicates that PS1 is active.

PS2 can be used as the stop signal for the reading phase.

All inputs are optocoupled and driven by a constant current generator; the command signal is filtered through an anti-disturbance circuit which generates a delay of about 5 ms for PS1 and PS2 and 500 μ s for ENC.

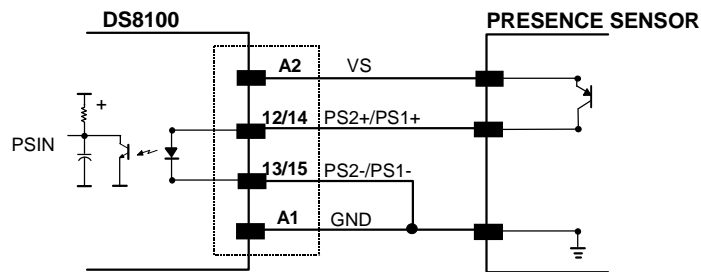

Figure 2.18 - Presence sensor input PNP command

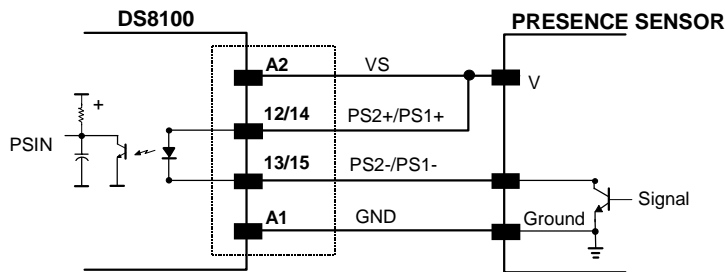

Figure 2.19 - Presence sensor input NPN command

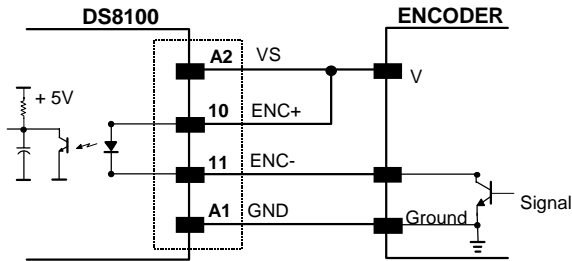

Figure 2.20 - Encoder NPN input command using DS8100 power

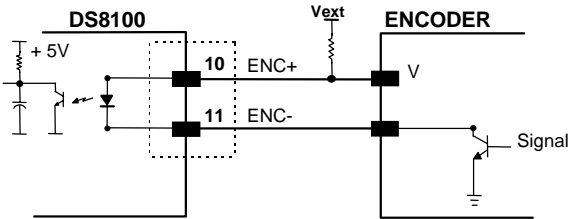

Figure 2.21 - Encoder NPN input command using external power

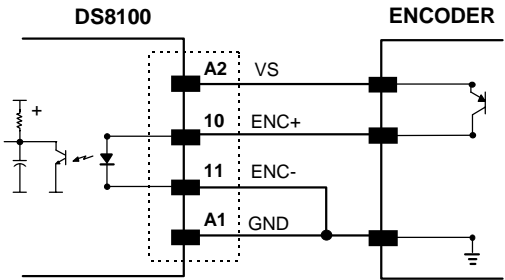

Figure 2.22 - Encoder PNP input command using DS8100 power

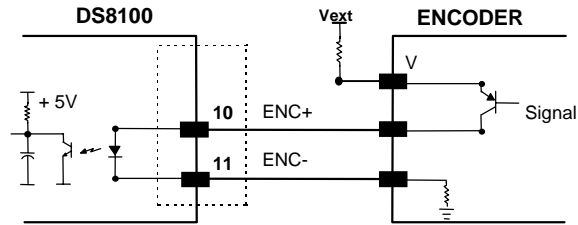

Figure 2.23 - Encoder PNP input command using external power

Isolation between the command logic and the scanner is maintained by powering the inputs with a different supply voltage (V_{ext}) from that supplied on the **Aux. Interface/Input Signal A** and **B** connectors (VS).

The driving logic of the input signals may be powered, for convenience, with the voltage supply between pins A2 (VS) and A1 (GND) of the connector. In this case, however, the device is no longer electrically isolated.

The electrical features of these inputs are:

Maximum voltage	30 V
Maximum current	25 mA

2.5.6 Outputs

The relative signals are available on the Output Signal connector (Figure A, 16).

Pin	Name	Function
1	VS	power for external devices (Positive pin)
2	GND	power for external devices (Negative pin)
3	NO READ+	no read output +
4	NO READ-	no read output -
5	RIGHT+	right code output +
6	RIGHT-	right code output -
7	I.U.	internal use
8	I.U.	internal use
9	N.C.	not connected

A D.C. output voltage, the same as that powering the DS8100, is present between pins 1 and 2. This may be used to power external devices: electrical isolation between the scanner and external devices is lost in this case.

The **No Read** output activates when a code signalled by the presence sensor is not decoded.

The **Right** output is used to signal the presence of a right code, thus a good decode condition.

All outputs are level or pulse programmable: a 50 ms pulse is generated in the second case. Further programming information is supplied in the WINHOST Help File.

These outputs are created using optoisolated Darlington drivers and supply both the collector and emitter in output, allowing both loads referenced to ground and to the power supply to be driven.

The electrical features are given below:

- Collector-emitter voltage 30 V Max.
- Collector current 130 mA Max (pulsed).
- Saturation voltage (VCE) 1 V at 10 mA Max.
- Maximum power dissipation 90 mW at 50 °C (Ambient temperature).

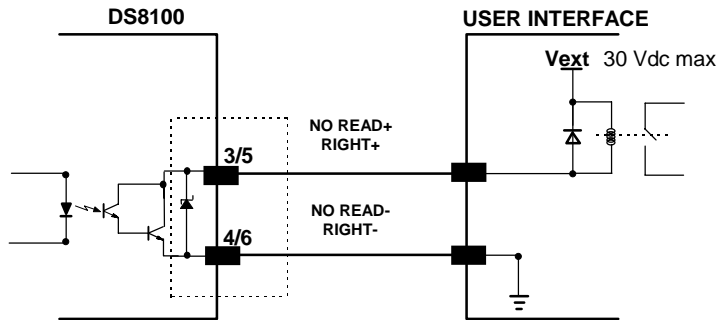

Figure 2.24 - Output interface

When the load is powered by an external power supply, the voltage must be less than 30 V. The limit requested by the maximum power dissipation is more important than that of the maximum collector current: if one of these outputs is continuously driven, the maximum current must not be more than 40 mA although 130 mA may be reached in pulse conditions.

2.6 POSITIONING

The DS8100 scanner is able to decode barcode labels at a variety of angles, however significant angular distortion may degrade reading performance.

When mounting the DS8100 take into consideration these three ideal label position angles: **Pitch 0°**, **Skew 0° to 45°** and **Tilt 0°**.

Follow the suggestions for the best orientation:

The **Pitch** angle is represented by the value **P** in Figure 2.25. Position the reader in order to minimize the Pitch angle.

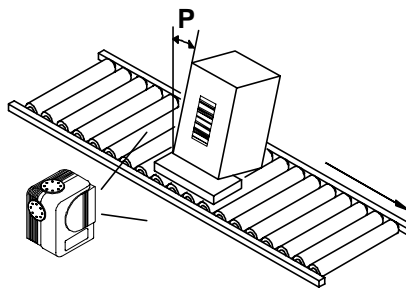

Figure 2.25 - "Pitch" angle

The **Skew** angle is represented by the value **S** in Figure 2.26.

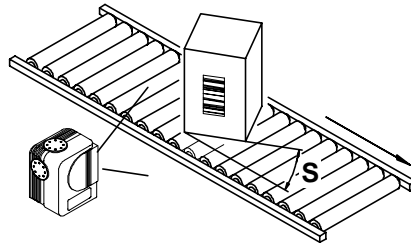

Figure 2.26 - "Skew" angle

The **Tilt** angle is represented by the value **T** in Figure 2.27. For code reconstruction, see par. 4.1.1.

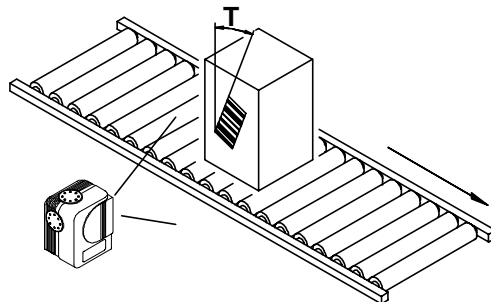

Figure 2.27 - "Tilt" angle

2.7 TYPICAL LAYOUTS

2.7.1 Standard (Point-to-Point)

In this layout, data is transmitted to the Host on the main serial interface. The selectable interface types are RS232, RS485 full-duplex or 20 mA C.L. communications.

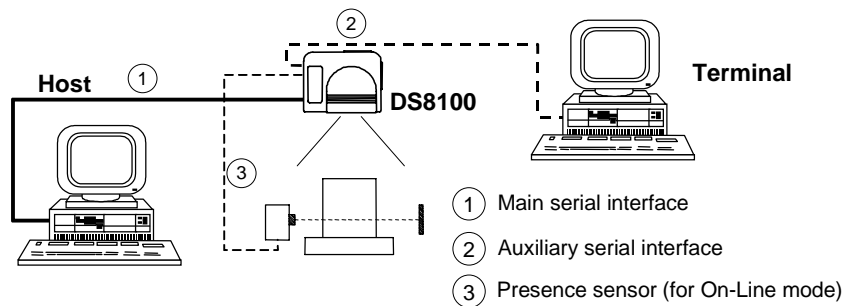

Figure 2.28 - Standard (point to point) layout

When On-Line Operating mode is used, the scanner is activated by an External Trigger (presence sensor) when the object enters its reading zone.

The data is also transmitted on the Auxiliary interface (if configured for Standard communication mode), as well as on the Main interface. The auxiliary interface uses RS232 for this layout.

Host Mode programming can be accomplished either through the Main or the Auxiliary interface.

2.7.2 Pass Through

Pass Through Mode allows two or more devices to be connected to a single external serial interface. The DS8100 transmits the messages received by its auxiliary interface (RS232 only) onto its main interface.

In this configuration a series of scanners can be connected together using RS232 on the main interface and all messages will be passed through this chain to the host.

The reading phase of each scanner is independent from the others in a Pass Through chain. *When On-Line Operating mode is used, the scanner is activated by an External Trigger (presence sensor) when the object enters its reading zone.*

Applications can be implemented to connect a device such as a hand-held reader to the Auxiliary port for manual code reading capability.

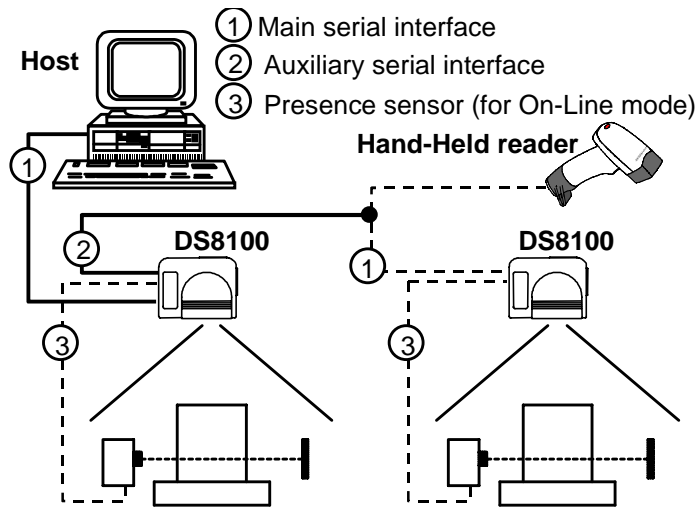

Figure 2.29 - Pass through layout

2.7.3 RS485 Master/Slave

The RS485 Master/Slave connection is used to collect data from several scanners to build either an omni-directional or multi-sided reading system; there can be one Master and up to 8 Slaves connected together.

The Master and Slave scanners are connected together using RS485 half-duplex on the auxiliary serial interface.

The Master scanner is also connected to either a Host or a Multiplexer on the main serial interface. The possible main interface type selections are RS232 or RS485 full-duplex for Host connections or RS485 half-duplex for Multiplexer connections (see “Main Interface Selection” in par. 2.3.1).

For the Slave scanners the Multidrop Address Selection can be made using the DIP switch. The addresses must be consecutive and not include zero for hardware configuration, or be selected in software (in this case the DIP switch address must be zero for each Slave). See par. 2.3.2.

NOTE

The main serial port of the Slave scanners can be used for configuration. The termination resistors of the RS485 bus must not be installed.

Single P.S.

The P.S. signal is unique to the system; there is a single reading phase and a single message from the master scanner to the Host.

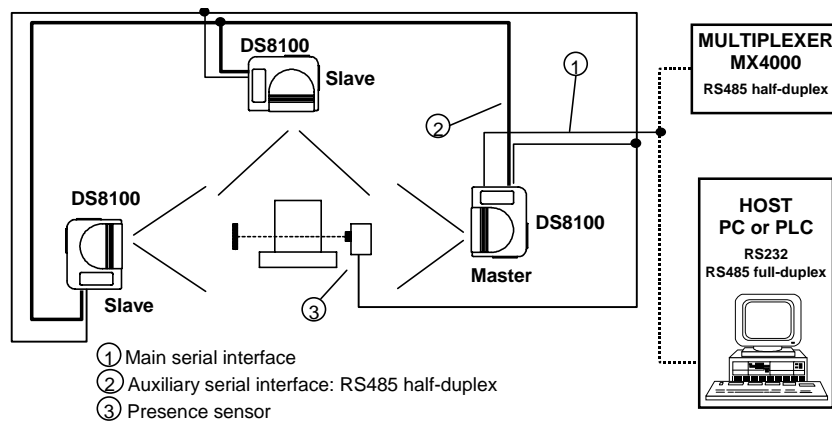

Figure 2.30 - Master-slave Single P.S. layout

Multi P.S.

In this layout, each DS8100 has its own P.S. and therefore multiple reading phases. The master sends the individual messages collected from the multidrop line as well as its own to the Host.

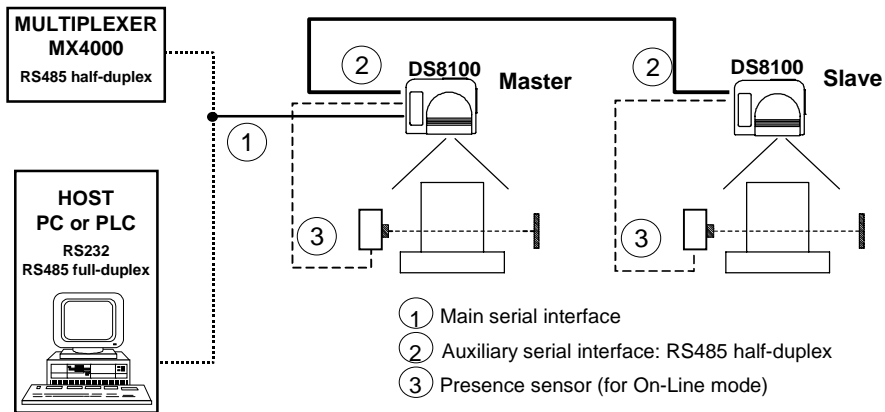

Figure 2.31 - Multi P.S. layout connections

2.7.4 Multiplexer

Each scanner is connected to an MX4000 using RS485 half-duplex on either the main or the auxiliary interface. The other interface can be used for configuration.

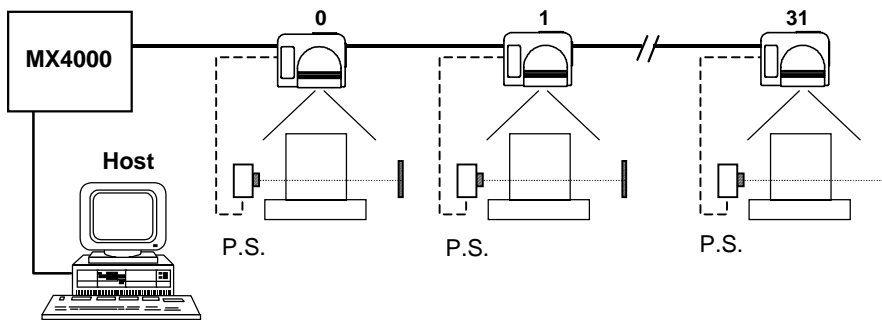

Figure 2.32 - Multiplexer layout

2.7.5 Omnidirectional Reading

Two or more scanners are correctly positioned in a Master/Slave Single P.S. type layout to compose an omnidirectional reading station.

The XMF series metal frames provide easy mounting for this type of layout.

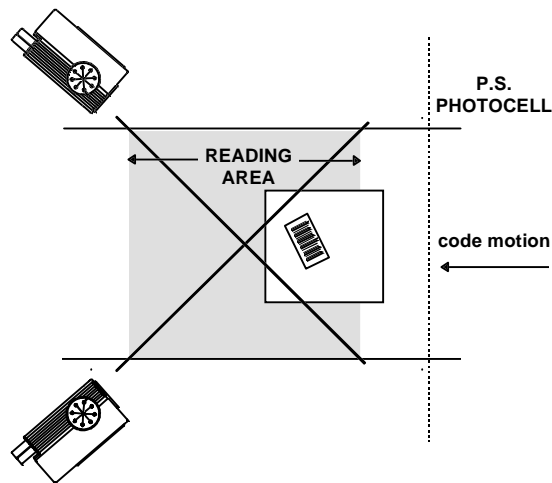

Figure 2.33 - Omnidirectional reading

3 INSTALLATION — DS8100 BUS INTERFACE

3.1 PACKAGE CONTENTS

Verify that the DS8100 reader and all the parts supplied with the equipment are present and intact when opening the packaging; the list of parts includes:

1. DS8100 reader
2. Installation Manual + barcode test chart
3. Mounting bracket and screws

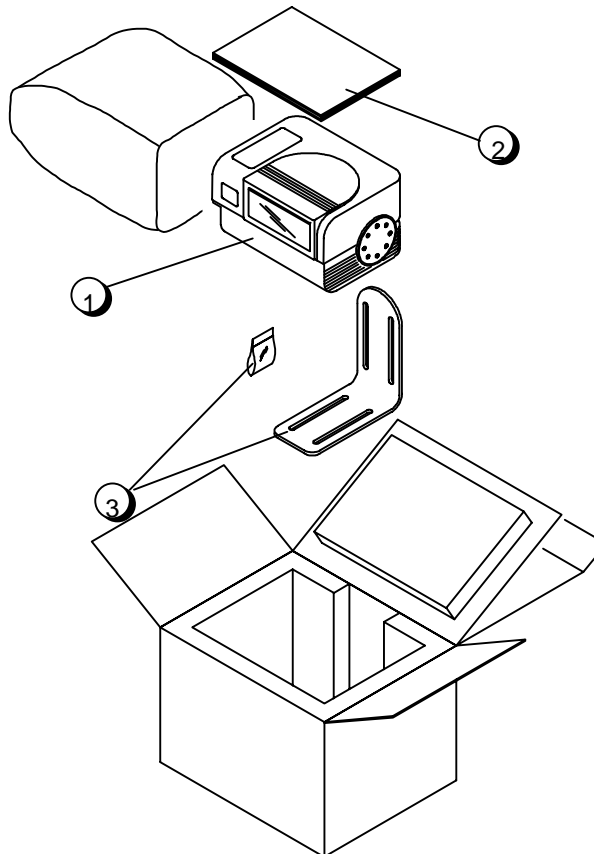

Figure 3.1 - DS8100 package contents

3.2 GUIDE TO INSTALLATION

The following can be used as a checklist to verify all the necessary steps for complete installation of the DS8100 scanner.

1. Read all information in the section Safety Precautions at the beginning of this manual.
2. Correctly position and mount the scanner for barcode reading according to the information in paragraphs 3.3 and 3.5.
3. Provide correct system cabling according to the signals necessary (see paragraph 3.4 and 3.6).
4. Configure your DS8100 by means of the SC8000 unit.

NOTE

Fine tuning of the scanner position for barcode reading can be accomplished by performing a test through the SC8000 unit.

The installation is now complete.

3.3 MECHANICAL INSTALLATION

DS8100 can be installed to operate in any position.

There are 16 screw holes (M6 X 8) on the sides of the scanner for mounting. The diagram below gives all the information required for installation; refer to par. 3.5 for correct positioning of the scanner with respect to the code passage zone.

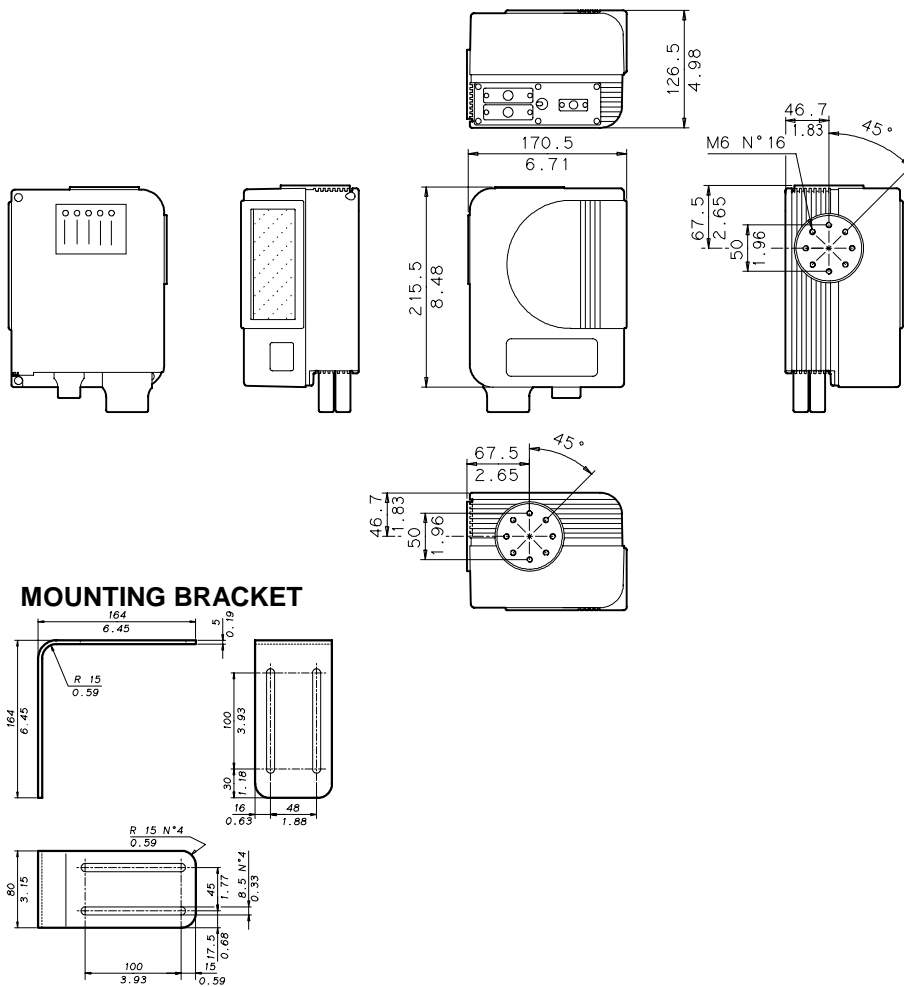

Figure 3.2 - DS8100 Bus Interface overall dimensions

3.4 ELECTRICAL CONNECTIONS

The DS8100 Bus Interface version employs a Lonworks network used for both input and output connections to build a multi-sided or omni-station system connecting several DS8100 scanners and one or more SC8000 units.

This version is equipped with the following 3 connectors:

- Lonworks INPUT male connector (17 pins) (Figure B, 12).
- Lonworks OUTPUT female connector (17 pins) (Figure B, 13).
- RS232 debug connector – for Service only, (9 pins) (Figure B, 14).

Lonworks INPUT/OUTPUT Connector

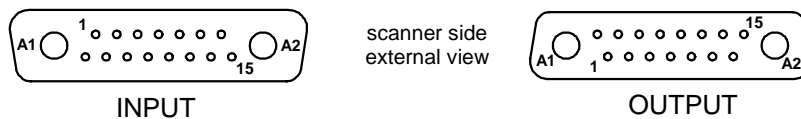

Figure 3.3 - Lonworks INPUT/OUTPUT connectors

The following pinout is valid for the INPUT connector as well as for the OUTPUT connector.

Lonworks INPUT/OUTPUT Connector pinout		
Pin	Name	Function
A1	GND	supply voltage (negative pin)
A2	VS	supply voltage 20 to 30 vdc (positive pin)
1	Shield A	
3	Shield B	
8	Lon A+	lonworks a line (positive pin)
9	Lon A-	lonworks a line (negative pin)
10	Lon B+	lonworks b line (positive pin)
11	Lon B-	lonworks b line (negative pin)
12	PS+	presence sensor
13	ENC+	encoder input
14	PSAux+	auxiliary presence sensor
15	Refer-	input reference

RS232 Debug Connector

The use of this connector is reserved for Service:

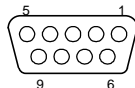

Figure 3.4 - RS232 debug connector

RS232 Debug Connector pinout		
Pin	Name	Function
2	TXD	transmit data
3	RXD	receive data
5	GND	ground

3.4.1 Power Supply

The supply voltage for correct operation of the scanner must be between 20 and 30 VDC.

The max. power consumption is 30 W.

The power block (optional), supplies the power necessary for the DS8100 and allows mains power to be used.

A security system allows the laser to activate only once the motor has reached the correct rotational speed; consequently, the laser beam is generated after a slight delay from the power on of the scanner.

The switch (Figure B, ) on the connector panel turns off power to both the motor and the laser beams.

During power up of the scanner there is a current peak of about 3A caused by the motor startup.

3.4.2 Inputs

The inputs for the DS8100 Bus Interface version are provided by SC8000 and are called ENC, PS and PSAux.

ENC is the Encoder input. In PackTrack™ operating mode, it detects the conveyor speed.

PS is the main presence sensor (external trigger). When active, this input tells the scanner to scan for a code and that decoding can take place. The yellow LED (Figure B, ⑥) indicates that PS is active.

PSAux can be used in special applications.

All inputs are optocoupled and driven by a constant current generator; the command signal is filtered through an anti-disturbance circuit which generates a delay of about 5 ms for PS and PSAux and 500 μ s for ENC.

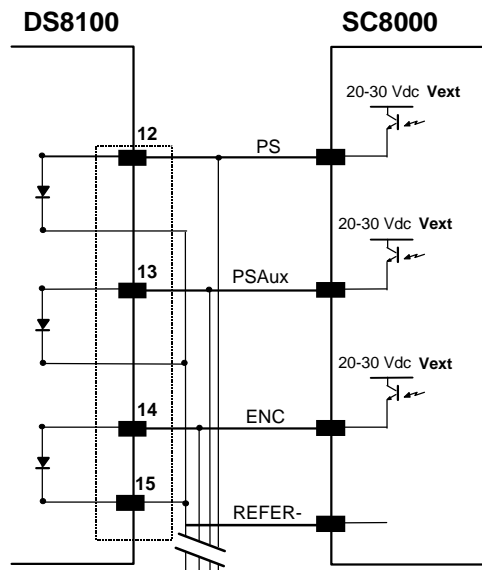

Figure 3.5 - DS8100 Bus Interface inputs

3.5 POSITIONING

The DS8100 scanner is able to decode barcode labels at a variety of angles, however significant angular distortion may degrade reading performance.

When mounting the DS8100 take into consideration these three ideal label position angles: **Pitch 0°**, **Skew 0° to 45°** and **Tilt 0°**.

Follow the suggestions for the best orientation:

The **Pitch** angle is represented by the value **P** in Figure 3.6. Position the reader in order to **minimize** the **Pitch** angle.

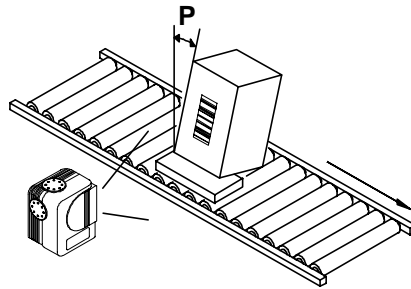

Figure 3.6 - "Pitch" angle

The **Skew** angle is represented by the value **S** in Figure 3.7.

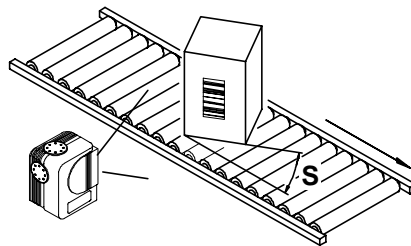

Figure 3.7 - "Skew" angle

The **Tilt** angle is represented by the value **T** in Figure 3.8. For code reconstruction, see par. 4.1.1.

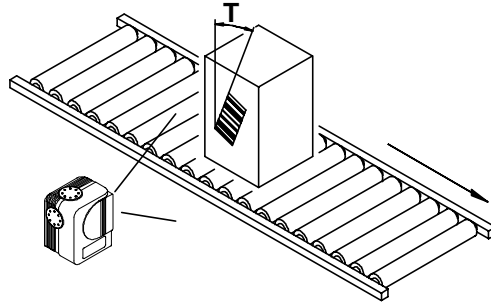

Figure 3.8 - "Tilt" angle

3.6 Typical Layout

The scanner is generally activated by a photoelectric sensor used as a code presence sensor when the object enters its reading zone.

The following figures show a typical layout for DS8100 Bus Interface.

A Lonworks cable provides a communication line (branch) between up to 4 scanners and an SC8000 unit. The last scanner on the line requires a Termination connector. Up to 4 branches of this type can be connected to a single SC8000. The allowed maximum length of the cable is 65 m.

External devices such as a presence sensor, an encoder and the supply unit are all connected to the SC8000, which collects all signals driving them to all scanners.

The SC8000 is also connected to a Host.

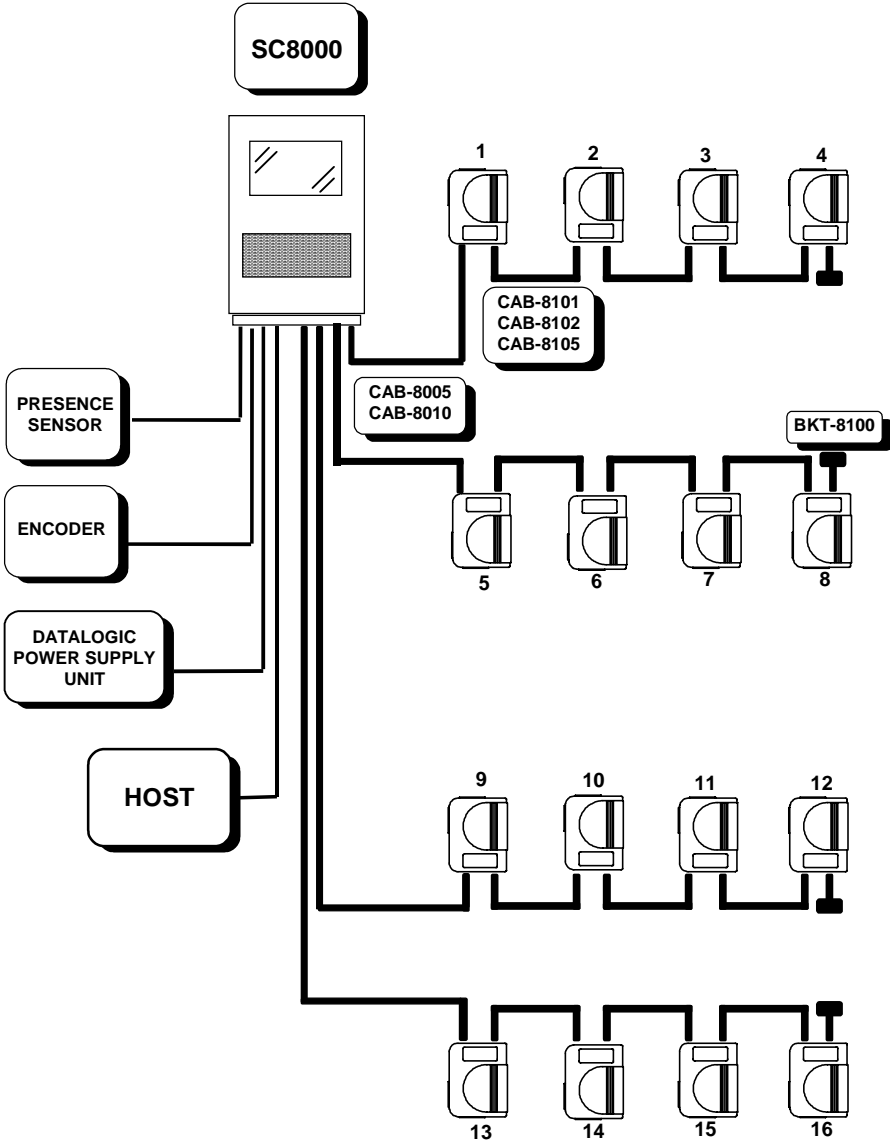

Figure 3.9 - DS8100 Bus Interface Typical Layout

DS8100

DATALOGIC

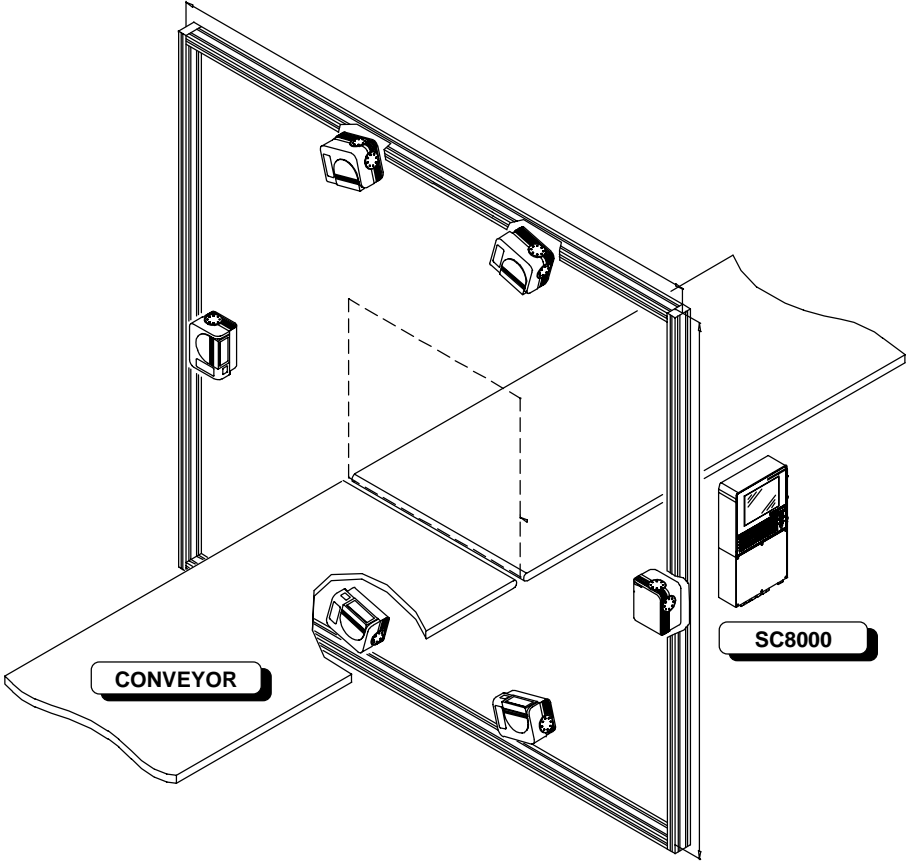

Figure 3.10 - DS8100 Bus Interface typical application

4 READING FEATURES

4.1 ADVANCED CODE RECONSTRUCTION

The traditional way of barcode reading could be called "Linear Reading". In this case, the laser beam crosses the barcode symbol from its beginning to its end as shown in Figure 4.1.



Figure 4.1 - Linear reading

In "Advanced Code Reconstruction" mode, it is no longer necessary for the laser beam to cross the label from the start to the end. With just a set of partial scans on the label (obtained using the motion of the label itself), the DS8100 is able to "reconstruct" the barcode. A typical set of partial scans is shown in Figure 4.2.

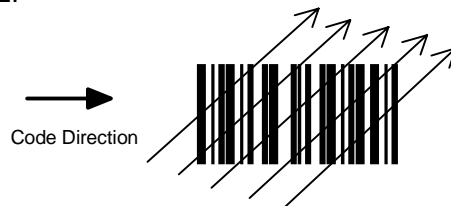

Figure 4.2 - Partial scans

None of the partial scans contains the whole label. The decoder aligns each partial scan correctly and combines them in order to obtain the entire code.

The alignment is performed by calculating the time difference from one partial scan to another using a reference code element.

4.1.1 Tilt Angle For Advanced Code Reconstruction

The most important parameter in Advanced Code Reconstruction is the value of the maximum tilt angle (α maximum) under which the code reconstruction process is still possible.

We define the Tilt angle as the angle (α) between the laser beam and a line parallel to the barcode label, as shown in Figure 4.3.

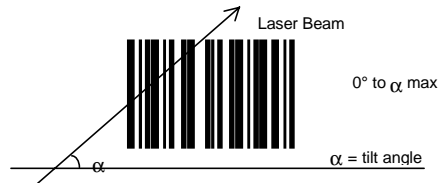

Figure 4.3 - Tilt angle

The formulas to calculate α maximum depend on various parameters such as: label height, number of scans per second, code motion speed, etc. To obtain α maximum for your application, please contact your Datalogic representative.

You must remember that the decoder will be able to read the label with a tilt angle between $+\alpha$ max and $-\alpha$ max as shown in Figure 4.4 (the shaded zones are the NO READ zones).

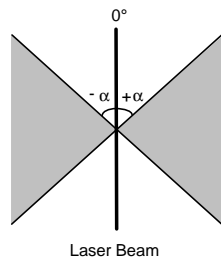

Figure 4.4 - Reading zones with α max

4.2 PERFORMANCE

The scan rate is 1000 scans/sec.

Refer to the diagrams in par. 4.3 for further details on the reading features. These diagrams are taken on various resolution sample codes at a 25 °C ambient temperature depending on the conditions listed under each diagram.

If standard models do not satisfy specific requirements, contact your nearest Datalogic distributor, supplying code samples, to obtain complete information on the reading possibilities.

4.2 - Reading features

4.3 READING DIAGRAMS

The following diagram shows the reading distance for barcodes with different densities for DS8100-2x00 (double laser models).

Note: (0,0) is the center of the laser beam output window

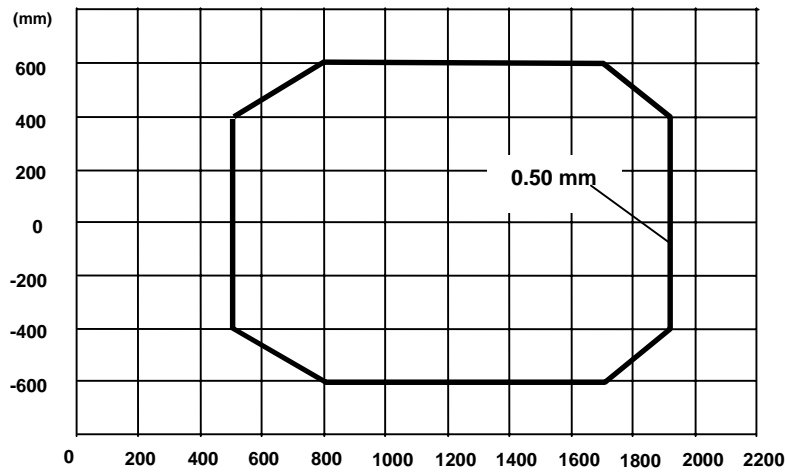

Figure 4.5 - Reading diagram for DS8100

- Code = Interleaved 2/5 or Code 39
- PCS = 0.90
- "Pitch" angle = 0°
- "Skew" angle = 10°
- "Tilt" angle = 0°
- Reading mode = Linear

The following diagram shows the reading distance for barcodes with different densities for DS8100-4x00 (quad laser models).

Note: (0,0) is the center of the laser beam output window

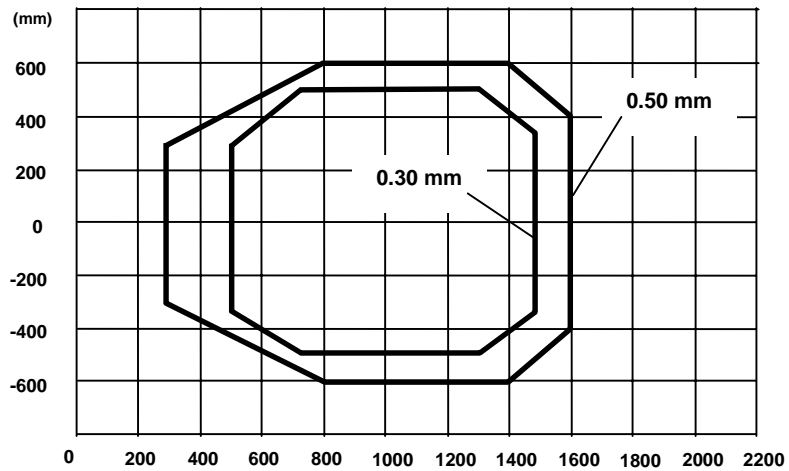

Figure 4.6 - Reading diagram for DS8100

Code	=	Interleaved 2/5 or Code 39
PCS	=	0.90
"Pitch" angle	=	0°
"Skew" angle	=	10°
"Tilt" angle	=	0°
Reading mode	=	Linear

4.4 - Reading features

5 MAINTENANCE

5.1 CLEANING

Clean the laser beam output window (Figure A and Figure B, ①) periodically for correct operation of the reader.

Dust, dirt, etc. on the window may alter the reading performance.

Repeat the operation frequently in particularly dirty environments.

Use soft material and alcohol to clean the window and avoid any abrasive substances.

WARNING

Clean the window of the DS8100 when the scanner is turned off or at least when the laser beam is not active.

DS8100

DATALOGIC

This page is intentionally left blank.

5.2 - Maintenance

6 TECHNICAL FEATURES

DS8100 model			
		Serial Interface	Bus Interface
ELECTRICAL FEATURES (see note 1)			
Maximum input voltage	35 Vdc		
Supply voltage	20 to 30 Vdc		
Operating current	1.3 - 0.9 A		
Power consumption	30 W		
INPUTS/OUTPUTS			
<u>Serial interfaces</u>			
Main	RS232 RS485 20 mA C.L.		Lonworks network
Auxiliary	RS232, RS485		
Baud Rates	1200 to 1.25 Mb/s		
Command inputs (NPN or PNP)	Presence sensor (optocoupled) Encoder input (optocoupled) Auxiliary input (optocoupled)		
Outputs (open emitter or collector)	NO READ (optocoupled) RIGHT CODE (optocoupled)		
OPTICAL FEATURES (see note 1)			
Light source	up to 4 semiconductor laser diodes		
Wave length	630 to 680 nm		
Safety class	Class 2 - IEC 825-1; Class II - CDRH		
Light receiver	Avalanche photodiode		
READING FEATURES			
Scan rate	1000 scans/s		
Maximum resolution Max. reading distance Max. reading width Max. depth of field Aperture angle	(see reading diagram in par. 4.3)		
USER INTERFACE			
	LCD Display: 2 lines, 20 characters		
	4 key keypad		
LED indicators	Power ON, Ext Trig, Encoder, Good Read, TX Data, User Defined	Power ON, Ext Trig, Encoder, Good Read, TX Data, Network.	

DS8100 model			
Serial Interface	Bus Interface		
SOFTWARE FEATURES			
Readable code symbologies	<ul style="list-style-type: none"> • Interleaved 2/5 • Code 39 Standard • EAN/UPC • Code 128 • EAN128 		
Code selection	Up to 5 code symbologies during one reading phase		
Decoding safety	Several good reads of the same code can be enabled separately for each code		
Headers and Terminators	Transmitted messages can be personalized using up to 4 headers and 4 terminators		
Operating modes	<table border="0" style="width: 100%;"> <tr> <td style="width: 50%;">ON LINE SERIAL ON LINE AUTOMATIC TEST PACK TRACK™</td> <td style="width: 50%;">Depending on SC8000</td> </tr> </table>	ON LINE SERIAL ON LINE AUTOMATIC TEST PACK TRACK™	Depending on SC8000
ON LINE SERIAL ON LINE AUTOMATIC TEST PACK TRACK™	Depending on SC8000		
Configuration modes	<table border="0" style="width: 100%;"> <tr> <td style="width: 50%;">WINHOST utility program <u>KEYBOARD MODE:</u> using the built-in keypad <u>HOST MODE:</u> receiving commands from the serial port</td> <td style="width: 50%;">SC8000</td> </tr> </table>	WINHOST utility program <u>KEYBOARD MODE:</u> using the built-in keypad <u>HOST MODE:</u> receiving commands from the serial port	SC8000
WINHOST utility program <u>KEYBOARD MODE:</u> using the built-in keypad <u>HOST MODE:</u> receiving commands from the serial port	SC8000		
Parameter storage	Non-volatile internal EEPROM		
ENVIRONMENTAL FEATURES			
Operating temperature	0 to 40 °C		
Storage temperature	-20 to 70 °C		
Humidity	90% non condensing		
Vibration resistance	IEC 68-2-6 test FC 1.5 mm; 10 to 55 Hz; 2 hours on each axis		
Shock resistance	IEC 68-2-27 test EA 30 G; 11 ms; 3 shocks on each axis		
Protection Class	IP64		
PHYSICAL FEATURES			
Mechanical dimensions	215.5 x 170.5 x 126.5 mm		
Weight	5 Kg		

Note 1: The features given are typical at 25 °C ambient temperature (if not otherwise indicated).

6.2 - Technical Features