

# OM2000 Oscillating Mirror Quick Reference Guide

**Description:**

The OM2000 oscillating mirror is an accessory for the 2000 series laser scanners: DS2100A, DS2400A. It is designed to generate homogeneous and adjustable raster reading through deflection of the scanning laser beam.

The system consists of the oscillating mirror attached to the scanner and allows a surface instead of a line to be observed; versatility and reading accuracy are therefore increased in "Picket Fence" reading mode.

Some examples are given in the following cases: codes presented at different "heights" on the reading surface; codes with printing defects.

The electronic and electromechanical components controlling the mirror movement are contained inside the rugged metal casing, which guarantees protection class IP65 when the OM2000 is mounted correctly onto the scanner.

The OM2000 is directly powered from the scanner through a connector which is accessible after removing the scanner cover (see assembly instructions on page 3). It therefore operates exclusively at low power, between 10 and 30 VDC.

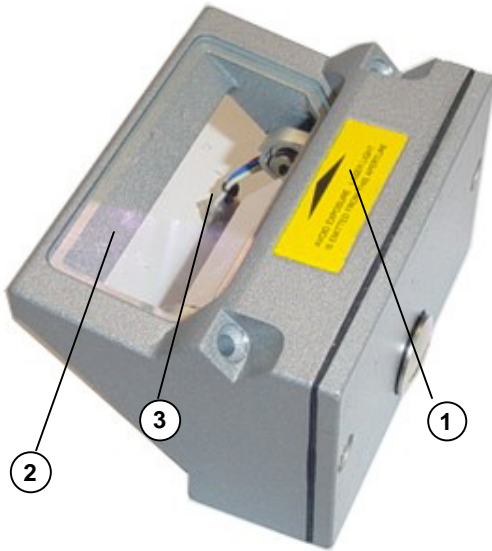

**Figure A**

- ① Warning Label
- ② Laser Beam Output Window
- ③ Power Cable

The following label is applied near the output window of the OM2000

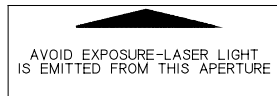

**Warning label**



**WARNING**

*Once the scanner-oscillating mirror reading system is assembled, the laser beam is emitted from the output window of the OM2000. All the precautions regarding laser exposure must be taken, (details are given in the Installation Manual of the scanner).*

**Technical Features:**

<b>ELECTRICAL FEATURES</b>	
<b>Operating voltage</b>	10 to 30 Vdc
<b>Input current max</b>	40 mA (RMS) @ 10 Vdc
<b>Power Consumption max</b>	1 W (RMS) @ 30 Vdc
<b>Raster width</b>	user adjustable from 10° to 40°(for further details see table 1 on page 4)
<b>Oscillation frequency</b>	user adjustable from 0.5 Hz to 4 Hz (for further details see table 1 on page 4)
<b>Response time</b>	1s max
<b>ENVIRONMENTAL FEATURES</b>	
<b>Operating temperature</b>	0° to +40 °C (+32° to +104 °F)
<b>Storage Temperature</b>	-20° to +70 °C (-4° to +158 °F)
<b>Humidity max</b>	90% non condensing
<b>Vibration Resistance</b>	IEC 68-2-6 test FC 0.5 G @ 9 to 150 Hz; x, y, z axis for 2 hours
<b>Shock Resistance</b>	IEC 68-2-27 test EA 30 G; 11 ms; 3 shocks x, y, z axis
<b>Protection Class</b>	IP65 (when correctly mounted to the scanner)
<b>PHYSICAL FEATURES</b>	
<b>Dimensions</b>	68x43x51,2 mm (2.68x1.69 x2.02 in)
<b>Weight</b>	approximately 160 g. (5.7 oz)

**Note:** the features indicated are to be considered typical at an ambient temperature of 25 °C (77 °F), if not specified differently.

**Mechanical Installation:**

When opening the packaging, verify that the OM2000 oscillating mirror is complete with a set of fixture screws, sealing gasket, and this installation manual.

Check that the output window of the scanner is clean, otherwise clean with soft material and alcohol; all abrasive substances must be absolutely avoided as they cause irreparable damage to the transparency of the glass.

**Mechanical Dimensions:**

The following figure gives the overall dimensions of the OM2000 and may be used for its installation.

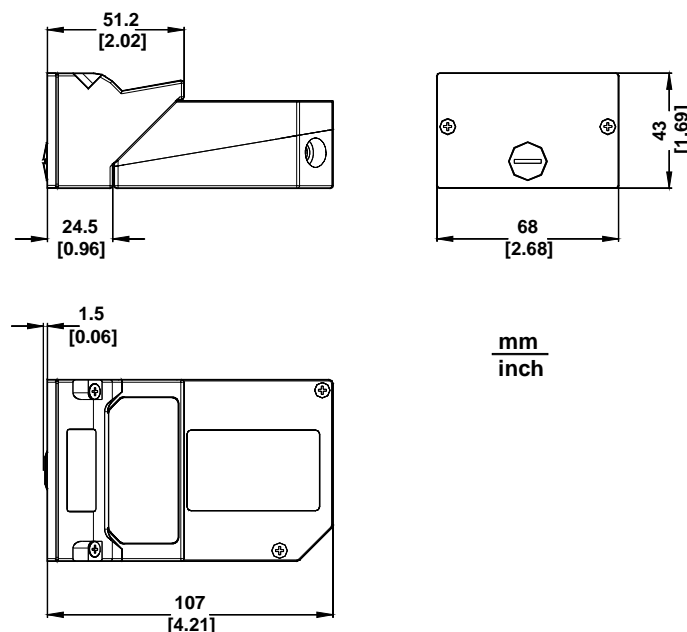
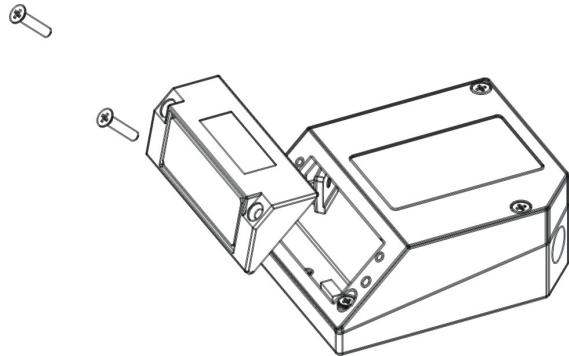

Figure 1 – Overall Dimensions

**Assembly to the Scanner:**

- 1) Clean the mirror surface with a clean soft cloth and alcohol before assembling it to the scanner.

- 2) Remove the scanner front cover (see Figure 2).



**Figure 2**

- 3) Bring the OM2000 close to the scanner and insert the cable into the power connector of the scanner (See Figure 3).

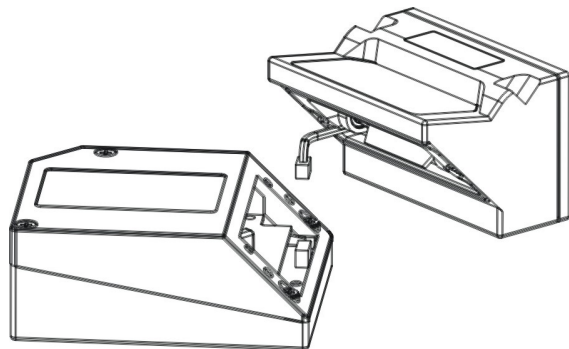

**Figure 3**

- 4) Check that the seal is correctly positioned and then after having aligned the OM2000 onto the scanner, fix it using the two screws supplied (see Figure 4).

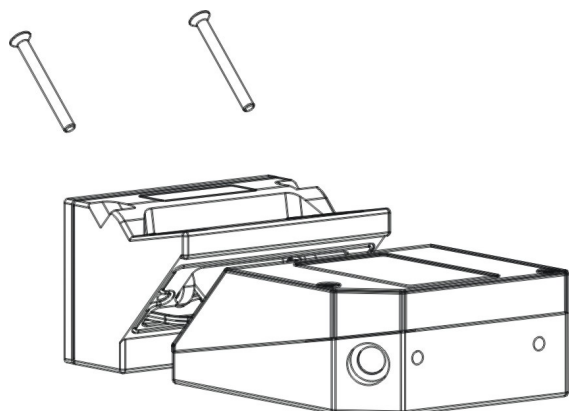

**Figure 4**

**Reading Features:**

The reading distance of the 2000 series scanner with the OM2000 is shifted by 10 mm towards the scanner because of the internal optical path between the scanner and the OM2000 output window.

The reading performance also decreases in typical conditions by about 10% due to the optical signal passing through the output window of the OM2000 and the reflection on the mirror surface.

The combination of these effects produces the reading diagram represented below:

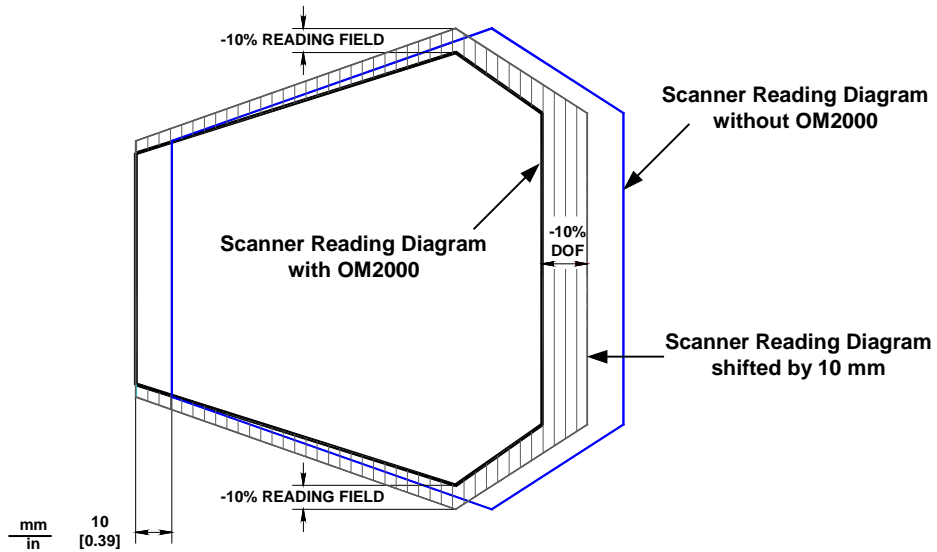

**Figure 5 – OM2000 Reading Performance Comparison**

The reading distance also depends on the amplitude of aperture used. In particular, wider apertures require the scanner to be closer to the code in order to read at the extreme edges of the sweep (see figure 6 below).

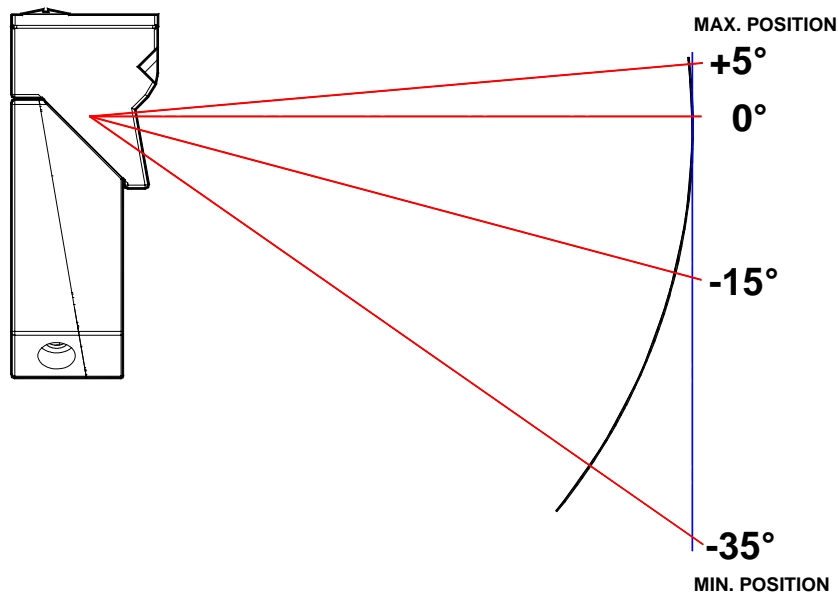

**Figure 6 – OM2000 Reading Distance**

**Adjustment:**

The OM2000 can be set to operate with different predefined oscillating frequencies and amplitude combinations (See figure 6 and table 1). In order to access the operating mode switch, you must remove the cover screw using the wide end of the adjustment tool as shown in figure 7 below. Then using the narrow end of the tool select the desired switch position as indicated in table 1.

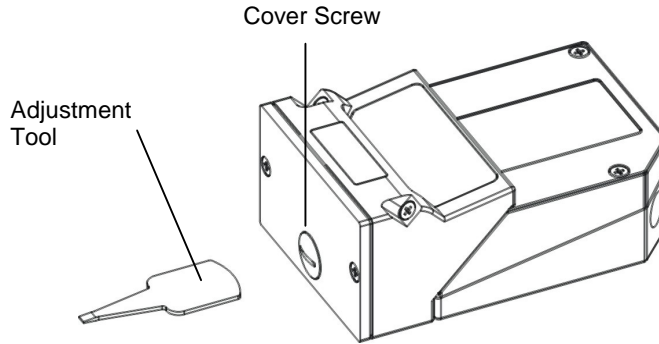

Figure 7 – Access to the Operating Mode Switch

Position	Amplitude	Max	Min	Frequency
0	10°	-10°	-20°	0,5
1	10°	-10°	-20°	1
2	10°	-10°	-20°	2
3	10°	-10°	-20°	4*
4	20°	-5°	-25°	0,5
5	20°	-5°	-25°	1
6	20°	-5°	-25°	2
7	20°	-5°	-25°	4*
8	30°	0°	-30°	0,5
9	30°	0°	-30°	1
A	30°	0°	-30°	2
B	30°	0°	-30°	4*
C	40°	5°	-35°	0,5
D	40°	5°	-35°	1
E	40°	5°	-35°	2
F	40°	5°	-35°	2

\* approximately

Table 1 – Allowable Switch Positions

The default switch position is **A** (Amplitude: 30°, Frequency: 2 Hz).

**Maintenance and troubleshooting:**

OM2000 has no user replaceable components and, apart from periodically cleaning the output window, no particular maintenance is necessary; dust and dirt on the surface may alter the reading performance of the system.

Clean the window with soft material and alcohol, absolutely avoiding all abrasive substances.



**WARNING** Do not remain in the laser beam output zone during these procedures.

If the device does not operate correctly, verify the connection to the scanner.



dichiara che  
declares that the  
déclare que le  
bescheinigt, daß das Gerät  
declare que el

**OM2000; OSCILLATING MIRROR** e tutti i suoi modelli  
and all its models  
et tous ses modèles  
und seine modelle  
y todos sus modelos

sono conformi alle Direttive del Consiglio Europeo sottoelencate:  
are in conformity with the requirements of the European Council Directives listed below:  
sont conformes aux spécifications des Directives de l'Union Européenne ci-dessous:  
der nachstehend angeführten Direktiven des Europäischen Rats:  
cumple con los requisitos de las Directivas del Consejo Europeo, según la lista siguiente:

<b>89/336/EEC EMC Directive</b>	e	<b>92/31/EEC, 93/68/EEC</b>	emendamenti successivi
	and		further amendments
	et		ses successifs amendements
	und		späteren Abänderungen
	y		sucesivas enmiendas

Basate sulle legislazioni degli Stati membri in relazione alla compatibilità elettromagnetica ed alla sicurezza dei prodotti.  
On the approximation of the laws of Member States relating to electromagnetic compatibility and product safety.  
Basée sur la législation des Etats membres relative à la compatibilité électromagnétique et à la sécurité des produits.  
Über die Annäherung der Gesetze der Mitgliedsstaaten in bezug auf elektromagnetische Verträglichkeit und Produktsicherheit entsprechen.  
Basado en la aproximación de las leyes de los Países Miembros respecto a la compatibilidad electromagnética y las Medidas de seguridad relativas al producto.

---

Questa dichiarazione è basata sulla conformità dei prodotti alle norme seguenti:  
This declaration is based upon compliance of the products to the following standards:  
Cette déclaration repose sur la conformité des produits aux normes suivantes:  
Diese Erklärung basiert darauf, daß das Produkt den folgenden Normen entspricht:  
Esta declaración se basa en el cumplimiento de los productos con las siguientes normas:

**EN 55022, August 1994:** LIMITS AND METHODS OF MEASUREMENTS OF RADIO DISTURBANCE CHARACTERISTICS OF INFORMATION TECHNOLOGY EQUIPMENT (ITE)

**EN 61000-6-2, April 1999:** ELECTROMAGNETIC COMPATIBILITY (EMC).  
PART 6-2: GENERIC STANDARDS - IMMUNITY FOR INDUSTRIAL ENVIRONMENTS

Lippo di Calderara, 18/08/2004

  
Ruggero Cacioppo  
Quality Assurance Supervisor